

Scotsman[®]

Ice Systems

SERVICE MANUAL

NW307/308/507/508_(22inch)

NW457/458/608/1008/1408_(30inch)

Electronic Modular Cubers (With Xsafe)

XSafe

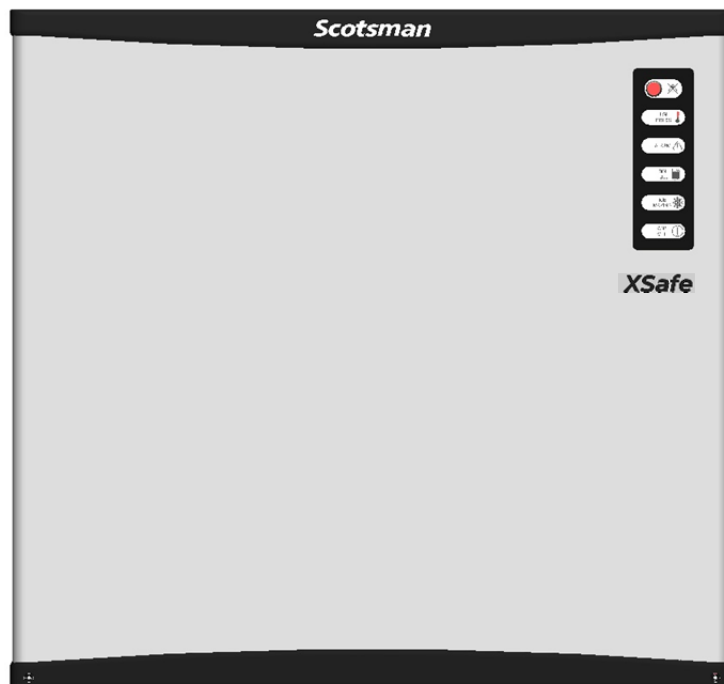

Part Number: 73000039-00

Version: F
For confirm

TABLE OF CONTENTS

Table of contents	1-2
Specifications	3-14

WARNING ATTENTION

WARNING ATTENTION FOR R290	15
----------------------------	----

FOR THE INSTALLER

Introduction	16
Storage bin	16
Standard legs	16
Important operating requirements	16
Select location	16
Ice machine	16-17
Air Baffle	17
AIR GRID	17
Stacking instructions	17

FOR THE PLUMBER

Conform to all applicable codes	17
Water inlet	17
Water inlet - cooling	17
Drains	18
Water drain - cooling	18

For the electrician

Electrical connections	18
------------------------	----

Final check list

19

START-UP

Start-up cycle	20
Freezing cycle	20-21
Harvest cycle	21

OPERATION

FREEZE CYCLY

Refrigeration during freeze	22
Water system	23

HAVEST CYCLE

Refrigeration system during harvest	24
Water system	24

Control sequence	25
-------------------------	----

Alarm conditions	25-26
-------------------------	-------

PC Board set up	27-28
------------------------	-------

SERVICE SPECIFICATIONS**Component**

Cube Size Control Float Valve Sensor	29
Reservoir Level	29
High Pressure Safety Switch	
Operating characteristics	29-30
Refrigerant charge value	31

Component description	32-34
------------------------------	-------

Closed Loop Scotsman® Sanitation System (XSAFE)	35-36
--	-------

WIRING DIAGRAM

NW 308	37
NW307/507/457	38
NW 508/458/608	39
NW 1008/1408 (230/50/1)	40
NW 1008 (400/50/3N)	41

SERVICE DIAGNOSIS	42
--------------------------	----

MAINTENANCE & CLEANING INSTRUCTION

Icemaker	43
Ice storage bin	43
Cabinet exterior	43
Cleaning (Icemaker)	43-44

SPECIFICATIONS

MODULAR CUBER NW 308/508



Ice Making Capacity

NW308 AIR COOLED MODELS 



°C °F	°F	50°	70°	90°	
	°C	10°	21°	32°	
10°	50°	160	130	100	kg
50°	10°	352	286	220	lbs
21°	70°	140	120	95	kg
70°	21°	308	264	209	lbs
32°	90°	120	105	90	kg
90°	32°	264	231	198	lbs
38°	100°	96	86	80	kg
100°	38°	211	189	176	lbs



NW308 WATER COOLED MODELS 



°C °F	°F	50°	70°	90°	
	°C	10°	21°	32°	
10°	50°	140	135	120	kg
50°	10°	308	297	264	lbs
21°	70°	145	125	110	kg
70°	21°	319	275	242	lbs
32°	90°	130	122	103	kg
90°	32°	286	269	227	lbs
38°	100°	120	115	99	kg
100°	38°	264	253	218	lbs



NW508 AIR COOLED MODELS 



°C °F	°F	50°	70°	90°	
	°C	10°	21°	32°	
10°	50°	213	200	170	kg
50°	10°	469	441	374	lbs
21°	70°	200	180	140	kg
70°	21°	441	396	308	lbs
32°	90°	160	145	130	kg
90°	32°	352	319	286	lbs
38°	100°	130	120	117	kg
100°	38°	286	264	258	lbs



NW508 WATER COOLED MODELS 



°C °F	°F	50°	70°	90°	
	°C	10°	21°	32°	
10°	50°	220	205	170	kg
50°	10°	485	452	374	lbs
21°	70°	210	200	160	kg
70°	21°	463	441	352	lbs
32°	90°	200	195	155	kg
90°	32°	441	430	341	lbs
38°	100°	190	180	150	kg
100°	38°	419	396	330	lbs



NOTE. To keep your Modular cuber performing at its maximum capacity, it is necessary to perform periodic maintenance as outlined in this manual.

SPECIFICATIONS



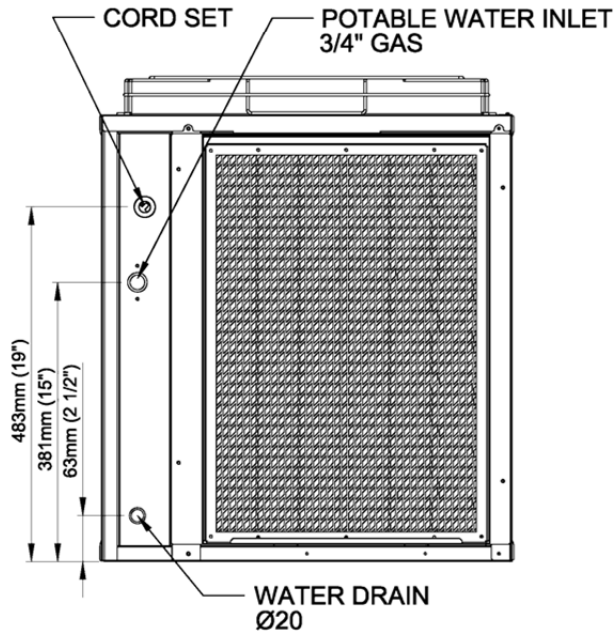
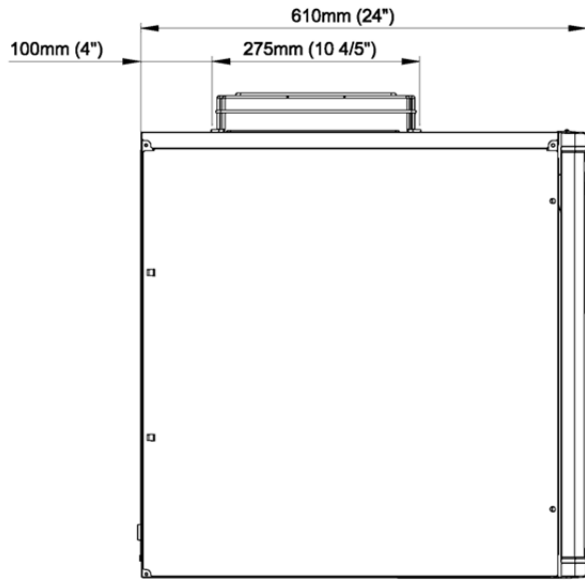
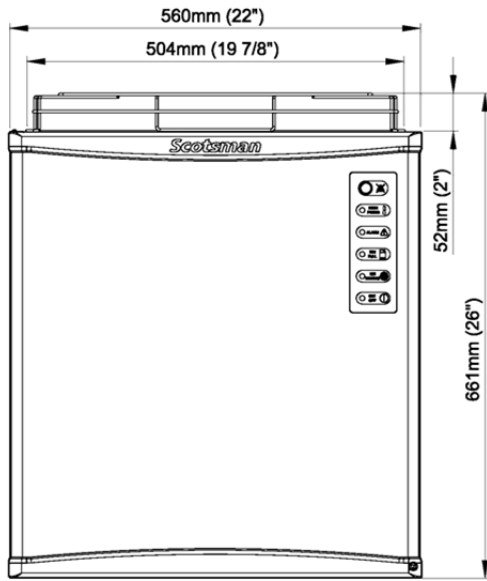



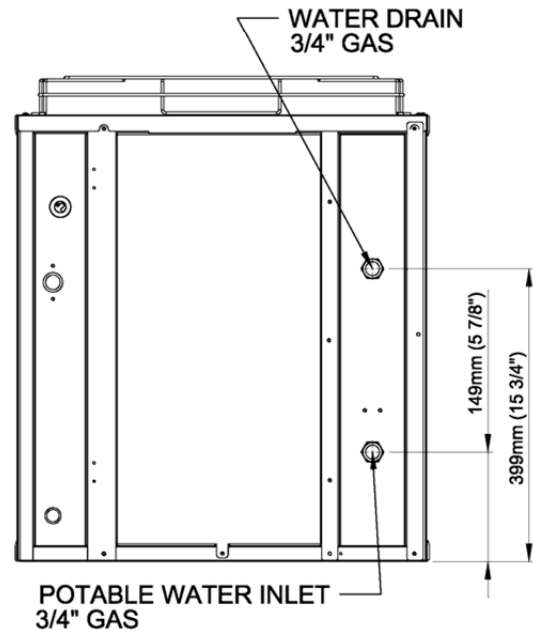









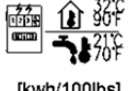



MODULAR CUBER NW 308/508



AIR COOLED



WATER COOLED

														
			[BTU/h]	[W]	[Ømm ²]	V/Hz/Ph	[W]	[A]	[kwh/100lbs]	[L/100lbs]	[kg]	[lbs]	[kg]	[lbs]
NW308AS			6142	1800	3x1.5	230/50/1	800	10A	7.4	80	55	121	70	154
NW308WS			6142	1800	3x1.5	230/50/1	700	10A	6	894	53	117	67	148
NW508AS			8872	2600	3x1.5	230/50/1	1200	16A	7.1	73	65	143	80	176
NW508WS			8872	2600	3x1.5	230/50/1	1000	16A	4.3	775	64	141	79	174

SPECIFICATIONS

MODULAR CUBER NW 307/507



Ice Making Capacity

NW307 AIR COOLED MODELS



°C \ °F	50°	70°	90°	
	10°	21°	32°	
10°	160	130	100	kg
50°	352	286	220	lbs
21°	160	125	100	kg
70°	352	275	220	lbs
32°	130	120	95	kg
90°	286	264	209	lbs
38°	100	90	85	kg
100°	220	198	187	lbs



NW507 AIR COOLED MODELS



°C \ °F	50°	70°	90°	
	10°	21°	32°	
10°	200	190	170	kg
50°	441	419	374	lbs
21°	190	170	140	kg
70°	419	374	308	lbs
32°	150	140	125	kg
90°	330	308	275	lbs
38°	120	110	100	kg
100°	264	242	220	lbs



NOTE. To keep your Modular cuber performing at its maximum capacity, it is necessary to perform periodic maintenance as outlined in this manual.

SPECIFICATIONS



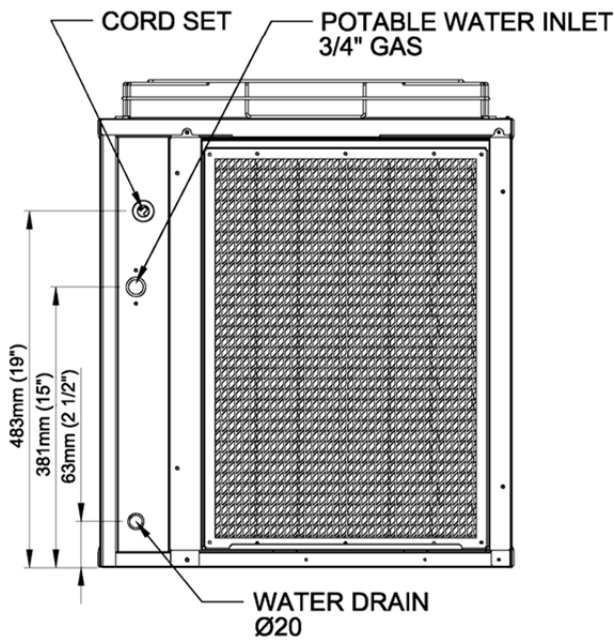
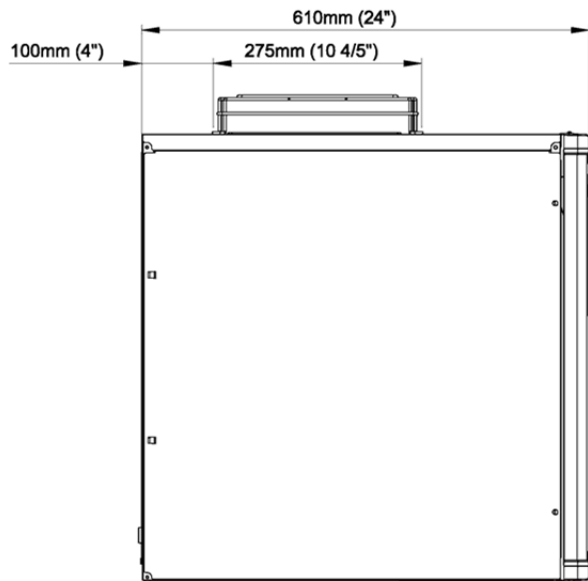
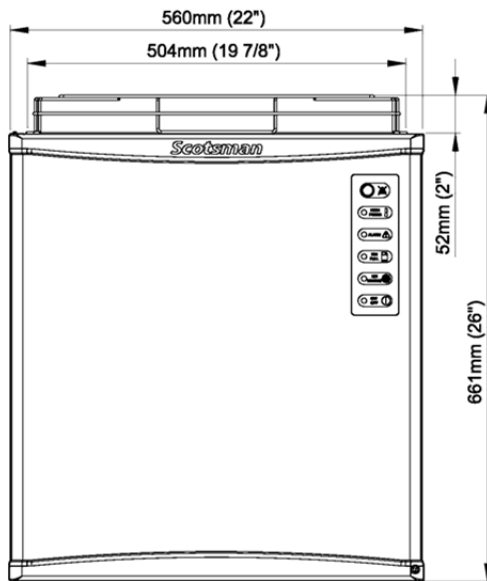



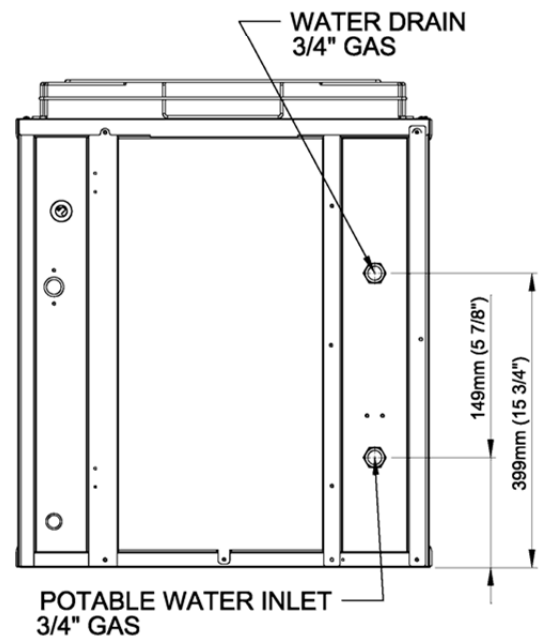



MODULAR CUBER NW 307/507



AIR COOLED



WATER COOLED

													
		[BTU/h]	[W]	[Ømm ²]	V/Hz/Ph	[W]	[A]	[kwh/100lbs]	[L/100lbs]	[kg]	[lbs]	[kg]	[lbs]
NW307AS		10035	2941	3x1.5	230/50/1	910	16 A	7.2	75	54	119	63	139
NW507AS		10035	2941	3x1.5	230/50/1	1210	16 A	6.6	80	67	148	77	170

SPECIFICATIONS

MODULAR CUBER NW 457/458



Ice Making Capacity

NW457 AIR COOLED MODELS 



°C \ °F	°F	50°	70°	90°	
	°C	10°	21°	32°	
10°	°F	215	195	175	kg
50°	°C	474	430	385	lbs
21°	°F	208	186	165	kg
70°	°C	458	410	363	lbs
32°	°F	155	150	132	kg
90°	°C	341	330	291	lbs
38°	°F	132	125	102	kg
100°	°C	291	275	225	lbs



NW458 AIR COOLED MODELS 



°C \ °F	°F	50°	70°	90°	
	°C	10°	21°	32°	
10°	°F	215	195	175	kg
50°	°C	474	430	385	lbs
21°	°F	200	186	165	kg
70°	°C	441	410	363	lbs
32°	°F	152	146	132	kg
90°	°C	335	322	291	lbs
38°	°F	132	125	118	kg
100°	°C	291	275	260	lbs



NW458 WATER COOLED MODELS 



°C \ °F	°F	50°	70°	90°	
	°C	10°	21°	32°	
10°	°F	200	187	167	kg
50°	°C	441	412	368	lbs
21°	°F	197	182	163	kg
70°	°C	434	401	359	lbs
32°	°F	180	165	153	kg
90°	°C	396	363	337	lbs
38°	°F	170	159	146	kg
100°	°C	374	350	322	lbs



NOTE. To keep your Modular cuber performing at its maximum capacity, it is necessary to perform periodic maintenance as outlined in this manual.

SPECIFICATIONS

MODULAR CUBER NW 457/458

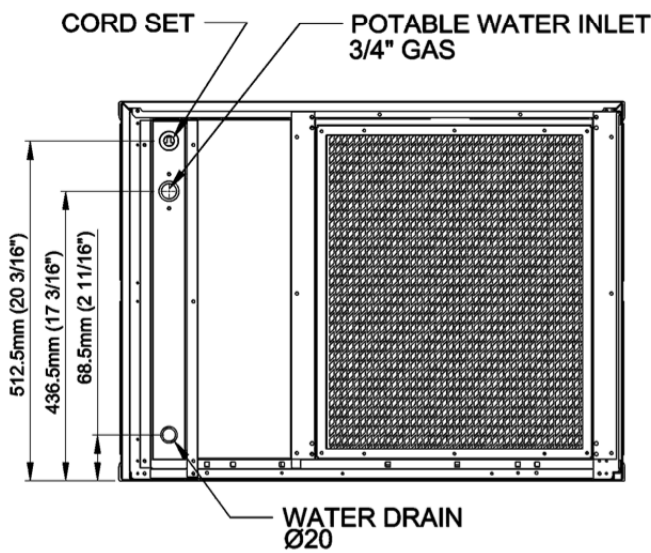
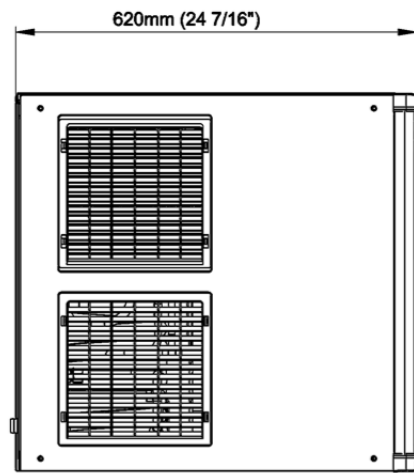
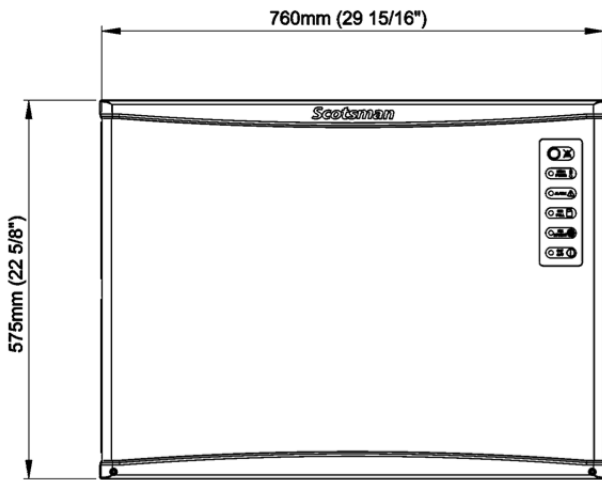

AIR COOLED

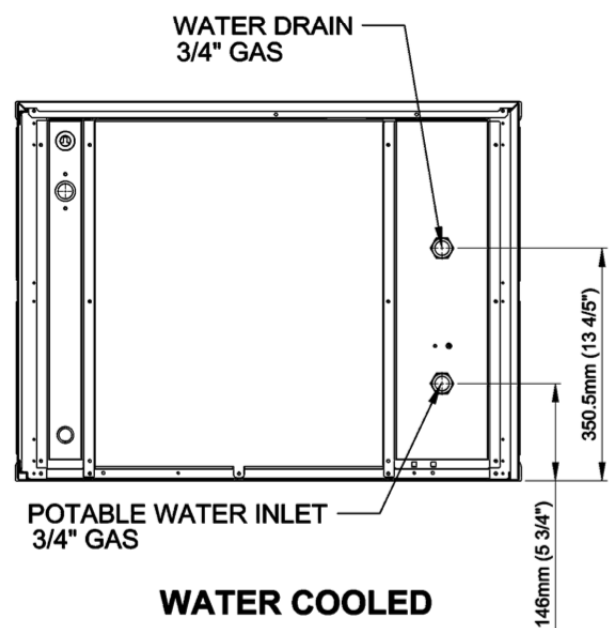

WATER COOLED

		[BTU/h]	[W]	[Ømm ²]	V/Hz/Ph	[W]	[A]	[kwh/100lbs]	[L/100lbs]	[kg]	[lbs]	[kg]	[lbs]
NW457AS		10035	2941	3x1.5	230/50/1	960	16 A	5.8	80	73	161	87	192
NW458AS		8900	2600	3x1.5	230/50/1	1000	16 A	6.47	57.6	70	154	85	187
NW458WS		8900	2600	3x1.5	230/50/1	900	16 A	5.8	825	69	152	84	185

SPECIFICATIONS

MODULAR CUBER NW 608



Ice Making Capacity

NW608 AIR COOLED MODELS 



°C \ °F	°F	50°	70°	90°	
	°C	10°	21°	32°	
10°	50°	320	290	260	kg
50°	10°	705	639	573	lbs
21°	70°	280	265	240	kg
70°	21°	617	584	529	lbs
32°	90°	225	210	195	kg
90°	32°	496	463	430	lbs
38°	100°	190	180	174	kg
100°	38°	419	396	383	lbs



NW608 WATER COOLED MODELS 



°C \ °F	°F	50°	70°	90°	
	°C	10°	21°	32°	
10°	50°	280	270	250	kg
50°	10°	617	595	551	lbs
21°	70°	275	265	245	kg
70°	21°	606	584	540	lbs
32°	90°	265	255	235	kg
90°	32°	584	562	518	lbs
38°	100°	250	240	225	kg
100°	38°	551	529	496	lbs



NOTE. To keep your Modular cuber performing at its maximum capacity, it is necessary to perform periodic maintenance as outlined in this manual.

SPECIFICATIONS

MODULAR CUBER NW608

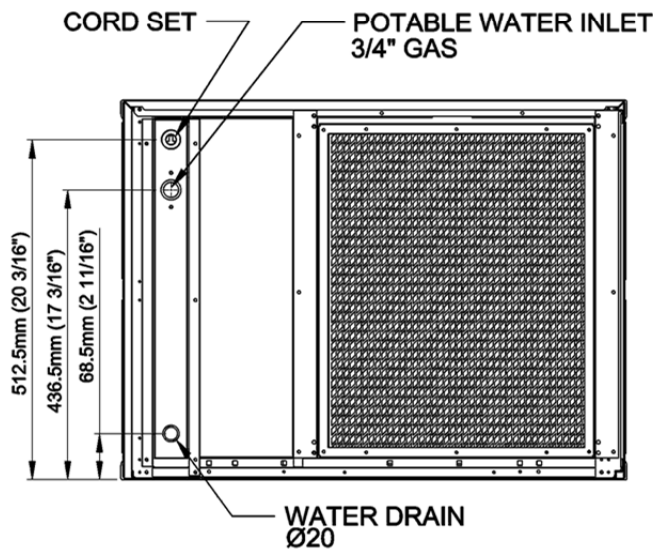
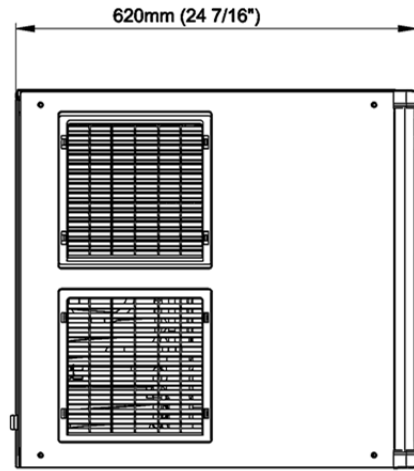
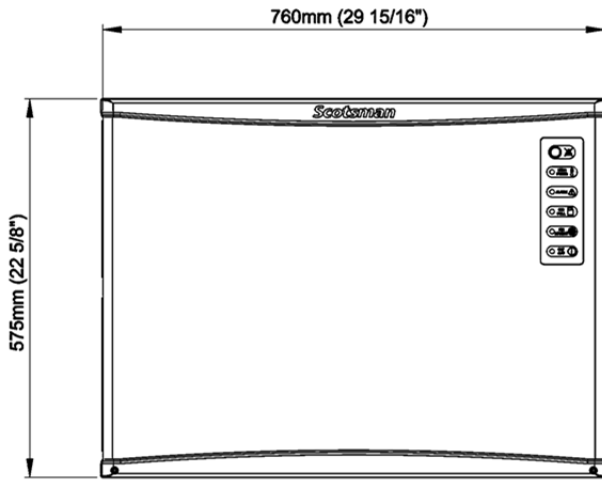

AIR COOLED

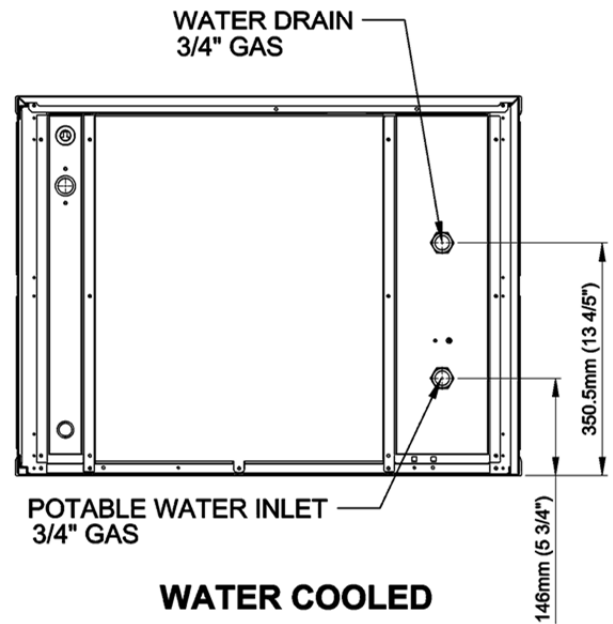

WATER COOLED

		[BTU/h]	[W]	[Ømm ²]	V/Hz/Ph	[W]	[A]	[kwh/100lbs]	[L/100lbs]	[kg]	[lbs]	[kg]	[lbs]
NW608AS		16600	4850	3x1.5	230/50/1	1600	16 A	7.41	65.6	73	161	88	194
NW608WS		16600	4850	3x1.5	230/50/1	1300	16 A	5.5	720	72	87	84	185

SPECIFICATIONS

MODULAR CUBER NW 1008



Ice Making Capacity

NW1008 AIR COOLED MODELS 



°C \ °F	50°	70°	90°	
	10°	21°	32°	
10°	485	457	430	kg
50°	1068	1007	947	lbs
21°	456	432	408	kg
70°	1004	952	899	lbs
32°	390	365	340	kg
90°	859	804	749	lbs
38°	330	315	300	kg
100°	727	694	661	lbs



NW1008 WATER COOLED MODELS 



°C \ °F	50°	70°	90°	
	10°	21°	32°	
10°	450	410	375	kg
50°	991	903	826	lbs
21°	445	405	370	kg
70°	980	892	815	lbs
32°	435	395	365	kg
90°	958	870	804	lbs
38°	415	380	355	kg
100°	914	837	782	lbs



NOTE. To keep your Modular cuber performing at its maximum capacity, it is necessary to perform periodic maintenance as outlined in this manual.

SPECIFICATIONS

MODULAR CUBER NW1008

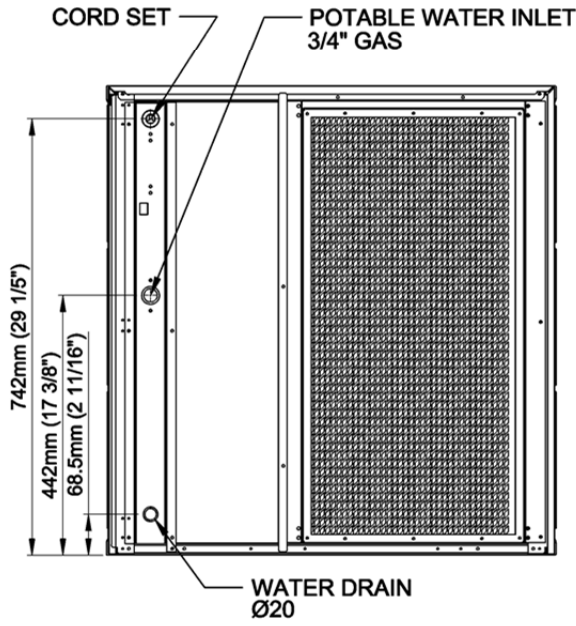
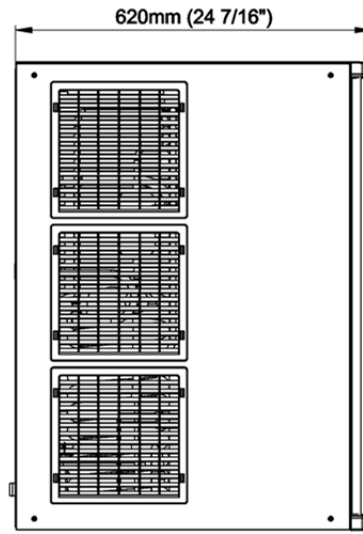
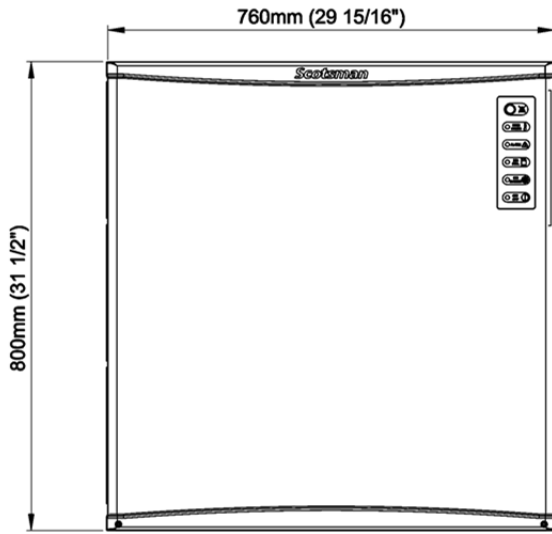

AIR COOLED

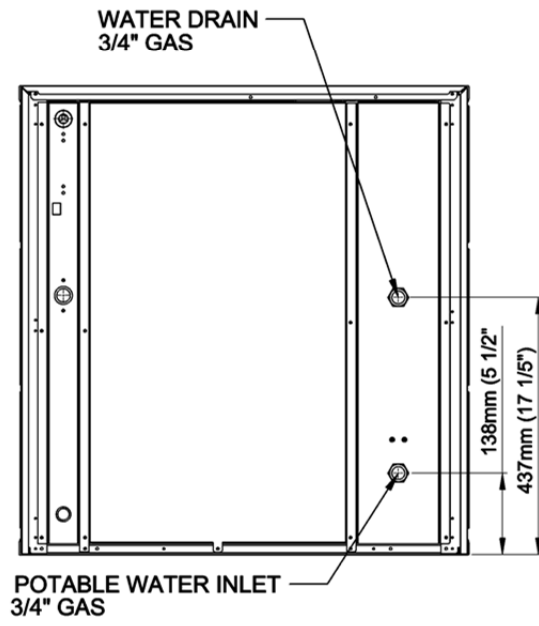

WATER COOLED

		[BTU/h]	[W]	[Ømm ²]	V/Hz/Ph	[A]	[kwh/100lbs]	[L/100lbs]	[kg]	[lbs]	[kg]	[lbs]
NW1008AS		24900	7300	5x2.5	400/50/3N	2500	10A	5.96	64.3	104	229	122 269
NW1008WS		24900	7300	5x2.5	400/50/3N	2500	10A	5.5	474.1	100	220	110 242
NW1008AS		24900	7300	3x2.5	230/50/1	2500	30A	5.96	64.3	104	229	122 269
NW1008WS		24900	7300	5x2.5	230/50/1	2500	30A	5.5	474.1	100	220	110 242

SPECIFICATIONS

MODULAR CUBER NW 1408



Ice Making Capacity

NW1408 AIR COOLED MODELS 



°C \ °F	°F	50°	70°	90°	
	°C	10°	21°	32°	
10°	50°	680	600	550	kg
50°	100°	1498	1322	1211	lbs
21°	70°	630	590	490	kg
70°	160°	1388	1300	1079	lbs
32°	90°	560	500	450	kg
90°	180°	1233	1101	991	lbs
38°	100°	504	403	370	kg
100°	212°	1110	888	815	lbs



NW1408 WATER COOLED MODELS 



°C \ °F	°F	50°	70°	90°	
	°C	10°	21°	32°	
10°	50°	680	630	550	kg
50°	100°	1498	1388	1211	lbs
21°	70°	660	620	520	kg
70°	160°	1454	1366	1145	lbs
32°	90°	630	600	500	kg
90°	180°	1388	1322	1101	lbs
38°	100°	590	550	490	kg
100°	212°	1300	1211	1079	lbs



NOTE. To keep your Modular cuber performing at its maximum capacity, it is necessary to perform periodic maintenance as outlined in this manual.

SPECIFICATIONS

MODULAR CUBER NW1408

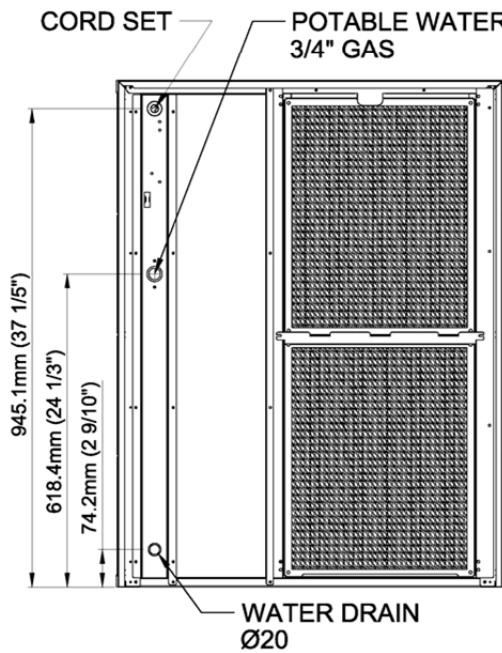
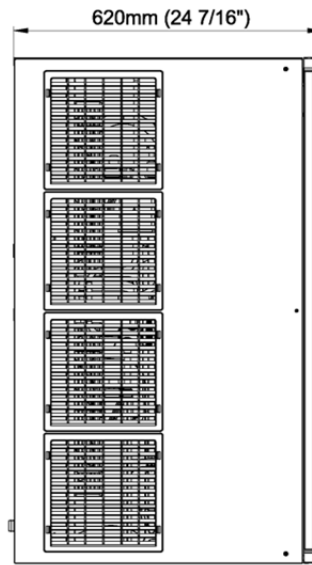
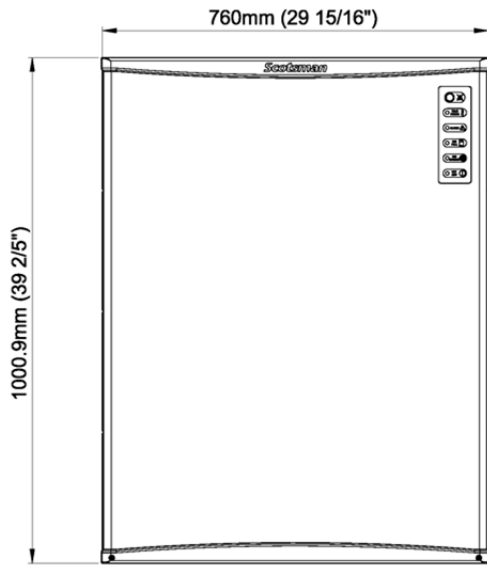

AIR COOLED

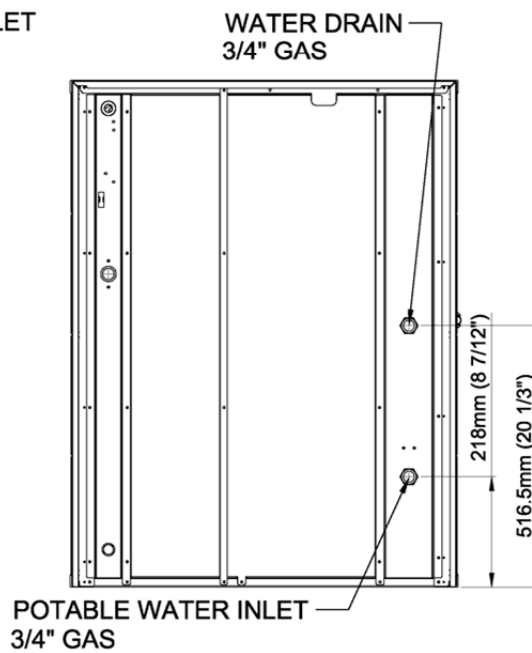

WATER COOLED

		[BTU/h]	[W]	[Ømm ²]	V/Hz/Ph	[W]	[A]	[kwh/100lbs]	[L/100lbs]	[kg]	[lbs]	[kg]	[lbs]
NW1408AS		35800	10500	3x2.5	230/50/1	3365	30 A	4.7	59	130	286	145	319
NW1408WS		35800	10500	3x2.5	230/50/1	3365	30 A	4.1	490	130	286	145	319

FOR NW307/507/457AS ONLY

WARNING ATTENTION



R290

- **Keep ventilation openings, in the appliance enclosure or in the built-in structure, clear of obstruction**
- **Do not use mechanical devices or other means to accelerate the defrosting process, other than those recommended by the manufacturer**
- **Do not damage the refrigerant circuit**
- **Do not use electrical appliances inside the food storage compartments of the appliance, unless they are of the type recommended by the manufacturer**
- **When positioning the appliance, ensure the supply cord is not trapped or damaged.**
- **Do not locate multiple portable socket-outlets or portable power supplies at the rear of the appliance**
- **Not having flame or hot surfaces within 1.5meters**
- **Switch located more than 1.5 meters and a height of 1.8m**
- **Only qualified personnel may work on the machine**

R290 Less than 150g

FOR THE INSTALLER

INTRODUCTION

These instructions provide the specifications and the step-by-step procedures for the installation, start up and operation for the SCOTSMAN Model NW series Modular Cubers. The Models NW series Modular Cubers are quality designed, engineering and constructed, and are thoroughly tested ices making systems, providing the utmost in flexibility to fit the needs of a particular user.

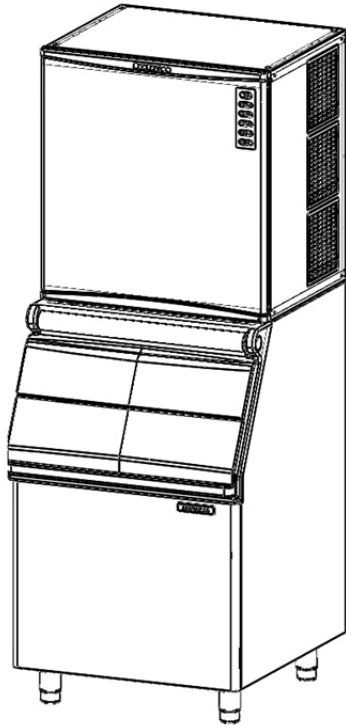

INSTALLATION NOTE: Allow 15 minimum space at sides and back for ventilation and utility connections.

STORAGE BIN

NW 307-308-507-508-457-458-608-808-1008-1408 can stack onto SCOTSMAN bin model NB 193-393-530-948 SCOTSMAN bin.

Other bins may be available with bin tops to vary the storage capacity. Lay the bin on its back, using cardboard from the carton to support it, screw in the legs.

Stand the bin upright, and correct any possible small tears in the machine mounting gasket with food grade silicone sealant.

Refrigerant R290/R404A/R452A

Charge per nameplate rating.

R290 only for NW307/507/457

STANDARD LEGS: Furnished with storage bin. Four legs screw into mounting sockets on cabinet base. Provide 14-17 cm height including adjustable leveling foot.

IMPORTANT OPERATING REQUIREMENTS

Air Temperature	MINIMUM 10 °C(50°F)	MAXIMUM 40°C (100°F)
Water Temperature	5°C (40°F)	35°C (90°F)
Water Pressures	1 bar gauge	5 bar gauge
Electrical Voltage Variations Voltage rating specified on nameplate	-10%	+10%

Extended periods of operation exceeding these limitations constitute misuse under the terms of Manufacturer's Limited Warranty, resulting in a loss of warranty coverage.

SELECT LOCATION

The first step in installing the equipment is to select the location. The purchaser of the unit will have a desired spot in mind, check out that spot to insure that it is:

- Indoors, in an environment that does not exceed the air and water temperature limitations for the equipment.
- That the necessary utilities are available including the correct voltage electrical power.
- that there be space around the installed machine for service, 15 cm. minimum left, right, and rear for air-cooled models.

ICE MACHINE

The use of a mechanical lift is recommended for lifting the uncrated icemaker onto the bin. Remove front, top and sides panels.

Place the unit directly onto the bin, align it with the back of the bin. Locate the hardware package, take out two mounting screws, and use them to secure the Icemaker to the two sides of the bin.

See illustration.

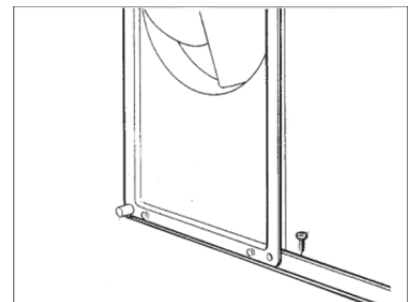

Remove all shipping material as well as the masking tapes from the ice Deflector evaporator cover.



AIR BAFFLE

Install on the back side of the machine the air baffle as per instruction provided with it.

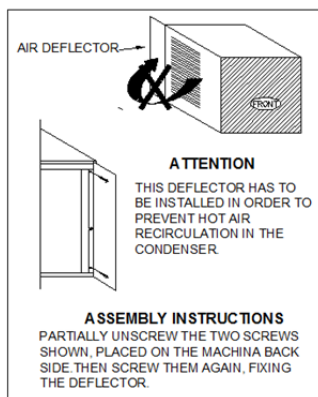

AIR GRID (NW307/308/507/508 ONLY)

Install on top panel of machine, as follow picture, for keep the ventilated space.



STACKING INSTALLATION

To stack a second NW onto the present one, first remove the top panel from the lower machine. Add a bead of food grade silicone sealant to the top edges of the lower units freezing compartment. Lift the top machine onto the bottom machine, (the use of a mechanical lift is recommended for this step). Align the two machines cabinets, and using the 2 screw from the top units, hardware package, fasten the two units together at the side cabinets.

Then make use of the Stacking Kit KSC 450, and KSC 1000, to be mounted as per fitting instructions included in their package, respectively on NW 458, NW608, NW1008 located in the bottom for proper conveying, of the ice cubes made by the top unit, into the storage bin.

With food grade silicone perfectly seal the edge between the freezing compartment of the upper machine and of the bottom machine so to avoid any possible leak of water through the clearance in between.

NOTE: NW 307/308/507/508/457/1408 NOT DESIGNED FOR STACKING.

FOR THE PLUMBER

CONFORM TO ALL APPLICABLE CODES

When choosing the water supply for the NW Cuber, consideration should be given to:

- A. Length of run.
- B. Water clarity and purity.
- C. Adequate water supply pressures.

Since water is the most important single ingredient in producing ice you cannot over emphasize the three items listed above. Low water pressure, below 1 bar may cause malfunction, of the icemaker unit. Water containing excessive minerals will tend to produce cloudy colored ice cubes, plus scale build-up on parts in the water system. Heavily chlorinated water can be controlled using charcoal or carbon filters.

WATER INLET

AIR-COOLED MODELS: The recommended water supply is cold water connected to the - 3/4" gas - male fitting at the back of the cabinet. Install a hand valve near the machine to control the water supply.

WATER INLET - COOLING

The recommended water supply is cold water connected to 3/4" gas - male fitting at the back of the cabinet. Install a hand valve near the machine to control the water supply.

DRAINS

AIR-COOLED MODELS: There is one 20 mm. diameter sump drain fitting at the back of the cabinet. Insulations in high humidity areas is recommended. The ideal drain receptacle would be a trapped and vented floor drain.

WATER DRAIN - COOLING

Connect to 3/4" gas - male fitting at the back of the cabinet. Install a hand valve near the machine.

STORAGE BIN: A separate gravity type drain needs to be run, similar to the air-cooled sump drain. Insulation of this drain line is recommended.

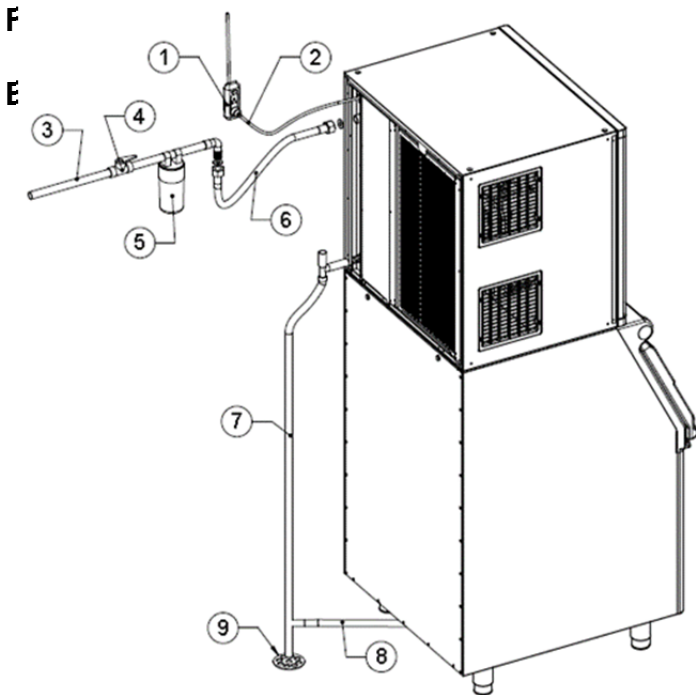

The unit comes equipped with an electrical cord for power supply. The lead wires must be connected to an electrical plug that corresponds to the local electrical codes and requirements or to a separate two poles disconnect box with opening to the contacts of about 3 millimeters. The disconnect box should be placed close to the selected ice maker location to be easily and promptly reached.

Undersized wiring or improperly installed electrical circuit will result in major problems and malfunctions. Voltage variations should not exceed ten percent.

IMPORTANT - All plumbing and electrical connections must be made by licensed plumbers and electricians, this one must follow the electrical specifications printed on the ice maker nameplate.

NOTE: All SCOTSMAN Cubers require a neutral wire and a solid earth ground wire to prevent possible severe Electrical Shock Injury to individuals or extensive damage to equipment.

- 1) Plug receptacle
- 2) Electrical plug
- 3) Water inlet
- 4) Shut-off valve
- 5) Water filter
- 6) Water inlet line
- 7) Water outlet line
- 8) Bin water outlet line
- 9) Open vented water drain

FINAL CHECK LIST

1. Is the cabinet/bin level?
2. Is the cuber in a location where ambient temperatures are a minimum of 10°C (50°F) all year around and to not exceed a maximum of 40°C. (100°F.)
3. Is there at least a 15 cm. clearance behind and around the cabinet for all connections and for proper air circulation?
4. Have all electrical and piping connections been made?
5. Has the electrical power supply wiring been properly connected and the voltage tested and checked against the nameplate rating? Has the unit properly grounded?
6. Is the water supply line shutoff valve installed and opened and has the inlet water supply pressure been checked to insure a minimum of 1 bar without exceeding a maximum of 5 bar.

7. Have the compressor hold down bolts been checked to be sure the compressor is snug on the mounting pads.

8. Check all refrigerant lines and conduit lines to against vibration and possible failure.

9. Has the cuber and the bin been wiped clean with clean damp cloths?

10. Has the owner/user been given the user manual and instructed on how to operate the icemaker and the importance of periodic maintenance?

11. Has the owner/user been given the name and telephone number of the authorized SCOTSMAN distributor or service agency serving him?

12. Has the manufacturer's registration card been properly filled out?

Check for correct Model and serial numbers from nameplate, and then mail the completed card to the manufacturer.

TYPICAL STACKING INSTALLATION

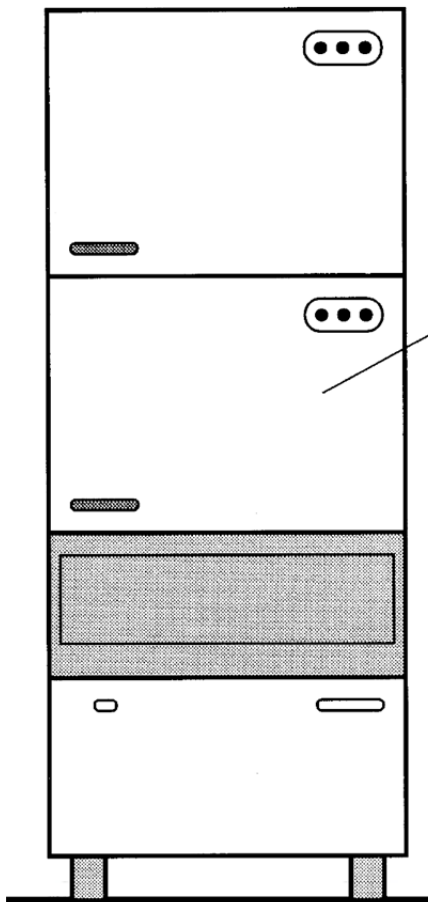

KIT STACKING KSC 450: TO STACK 2 NW 458 or NW608.
KIT STACKING KSC 1000: TO STACK NW 1008.
NW307/308/507/508/457/1408 NOT DESIGNED FOR STACKING.

START-UP

START-UP CYCLE

1. Open the water tap/valve and switch ON the power on the electrical supply line.

2. The models NW307-308-507-508-457-458-608 enter in the Start Up cycle with the PC Board energized, and NW1008/1408 enter in 90 minutes delay time controlled by PC Board, The LED of ICE MAKING blinking slow.

In Start Up cycle the LED of ICE MAKING and BIN FULL are energized, blinking slow 3 minutes for water system clean, then ICE MAKING blinking fast 40 second for pressure balance.

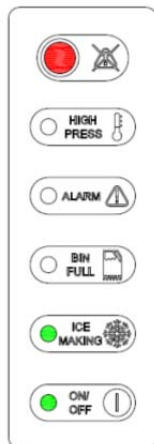

2. The LED energized are:

- Machine under power (steady)
- Machine in ICE MAKING (steady)

3. Water is coming into the water through the Water Inlet Solenoid Valve till the water reservoir is filled up to the maximum level controlled by a Water Level Sensor.



4. 40 seconds later, the Water Pump starts up.

5. After few minutes (3-5) from the start up of the freezing cycle, the Water Inlet Solenoid Valve is activated again for few seconds to refill the water reservoir up to the maximum level so to reduce any possibility of slush ice formation.

6. In the meantime the condenser sensor starts to transmit the current to the PC Board keeping in operation the Fan Motor in ON-OFF mode or continuously according to the condenser temperature.

NOTE:

Model NW 1008/1408 has a crankcase heater in the compressor. When the main power to the machine is switched ON, there is a time delay of 90 minutes during which only the compressor heater is energized with Green ICE Making LED Blinking slowly. However, if the ambient temperature is higher than 25°C (77°F), PC Board will automatically bypass this delay.

This time delay can also be bypass by pressing the bypass switch located at the back of the machine.

NOTE: Do not remove the evaporator deflector cover as it will cause the switching off of the machine at "STORAGE BIN FULL".

3. During the start up cycle the components in operation are:

- Hot Gas valve
- Water Drain Valve
- Water Inlet Valve
- Water Pump

FREEZING CYCLE

1. After the start up cycle the machine enters directly into the freezing cycle with the following components energized:

- Water Inlet valve
- Compressor
- Fan motor.

7. The machine remains in the freezing cycle with the ice that become thicker till the Float Valve Sensor ball going to top position.

8. When the Power is transmitted back to the PC Board continuously when Float Valve Sensor ball going to top for more than 6", the machine enters in the Pre-Harvest or directly into the Harvest Cycle mode according to:

• FAN MOTOR IN ON-OFF MODE DURING

Rise up the cutting temperature of the condenser sensor to 38°C (fan motor off) and extend the length of freezing cycle by 30" more the going to harvest cycle.

• FAN MOTOR ALWAYS IN OPERATION

Go straight to the harvest cycle.

9. First freezing time will range between 15 and 20 minutes. Longer time for temperature

above 25°C and shorter time required when temperature are below 25°C. Average complete cycle time is about 22 min.

HARVEST CYCLE

1. During the harvest cycle the components in operation are:

- Hot Gas valve
- Water Drain/Purge Valve
- Water Pump (According DIP Switch #6)
- Compressor
- Harvest Assist (For NW307/507/457 only)

2. The LED energized are:

- Machine under Power (steady)
- Machine in Harvest (steady)

3. After beginning of Harvest Cycle, Purge Valve will according DIP Switch (#6) setup to purge water, 20" after the Purge Valve open, the Water Inlet Solenoid Valve is energized for 10 seconds only in order to have a short flush of fresh water into the sump while the Water Pump and Purge valve are still in operation.

3. The Fan Motor remains in OFF mode unless the Condenser Sensor probe rise up to more then 38°C (same set up as per end of freezing cycle).

4. When the ice plate is falling down from the evaporator, the magnetic switch is activated for a while providing the signal to the PC Board to restart a new freezing cycle.

5. Observe first ice cube harvest and check size of ice cubes; if an adjustment is required loose screw as shown on below illustration.

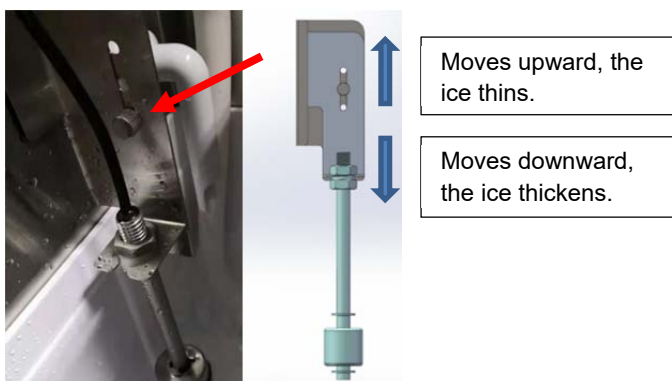

After loose screw, move the bracket thus keeping the ice cube at a proper thickness.

NOTE: This type of machine produce an "ICE PLATE" that breaks when falls down into the storage bin. Setting the float valve sensor in order to have single ice cubes may cause malfunction of the machine.

6. Observe second and third cube harvest. Check if size and shape combination is correct. In areas where extreme problem water conditions exist, filtering or purifying equipment is recommended.

NOTE:

A safety system built in the P.C. Board switches the unit on harvest cycle whenever the freezing period gets longer than 30' or 40'.

7. Check operation of magnetic switch controlling it by keeping open the bottom end of plastic deflector for more than 30 seconds. The machine must switch off at storage bin full. Release the plastic deflector. The machine should restart in the freezing cycle mode within few seconds going through a 3' delay time.

8. Place again all cabinet panels and screws previously removed.

9. Thoroughly explain to owner/user the significant specifications of the ice maker startup, reset and operation, going through the procedures in the operating instructions. Answer all questions about the ice maker by the owner and inform the owner himself of the name and telephone number of the authorized service agency serving him.

OPERATION

FREEZE CYCLE

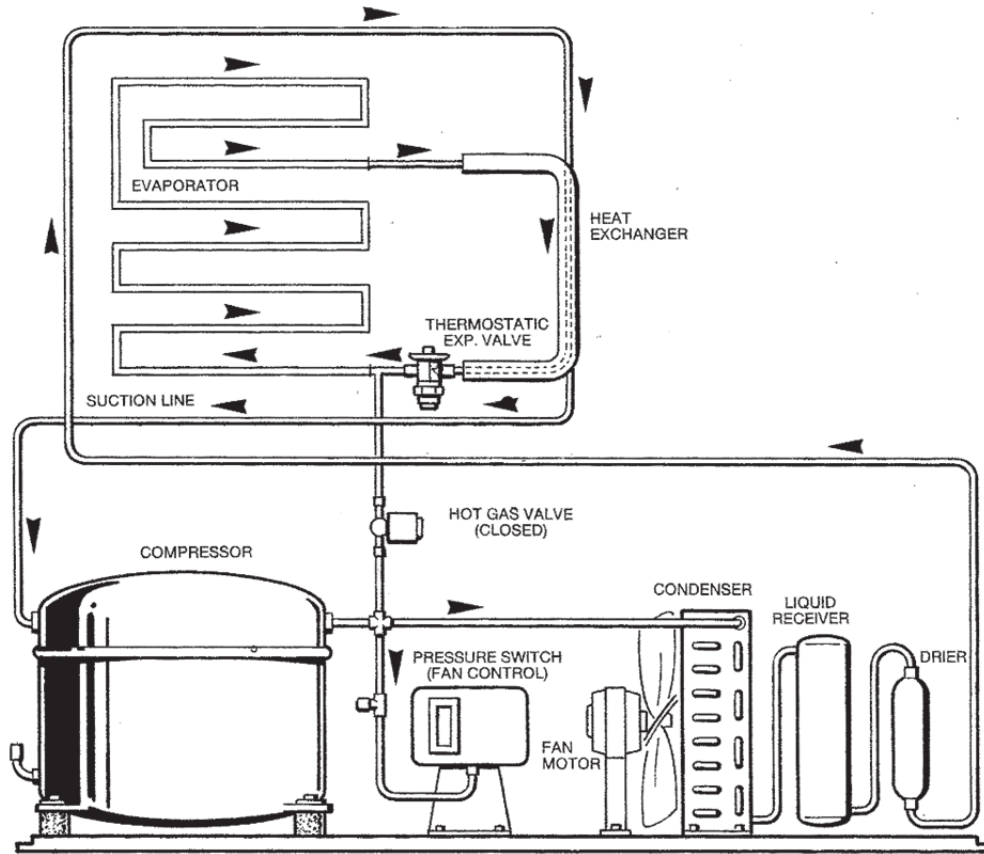

REFRIGERATION SYSTEM SCHEMATIC

REFRIGERATION DURING FREEZE:

This ice machine employs either air or water as a condensing media, the refrigeration system for either one is as follows:

At the hermetic compressor, Refrigerant is compressed into a high temperature, high pressure gas.

The gas moves through the discharge line into the condenser, air or water-cooled. If air-cooled, the discharge pressure will change with the heat load and the ambient air temperature.

If water-cooled, the discharge pressure is controlled by the amount of water flowing through the condenser - which is determined by the water regulating valve.

After the gas is cooled in the condenser, giving up much of its heat, the gas condenses into a high pressure liquid. This liquid travels through the liquid line to the metering device, a thermostatic expansion valve.

The thermostatic expansion valve meters how much liquid refrigerant is to be allowed into the

evaporator section of the refrigeration system. This is determined by the temperature of the TXV sensing bulb, located on the suction line manifold, at the outlet of the evaporator.

If the bulb senses a warm suction line, more refrigerant is allowed into the evaporator, (common at the beginning of the freeze cycle) and when the temperature begins to fall, less refrigerant is allowed through.

This is why the suction side gauge pressure will decline throughout the freeze cycle. At the evaporator, the liquid refrigerant released from high pressure, boils off in the low pressure environment and absorbs heat, thus cooling the evaporator surface and anything near it, such as water.

The low pressure refrigerant vapor then is forced through the heat exchanger where any excess liquid refrigerant boils-off, allowing only refrigerant vapor to enter the compressor suction tube, where it is recompressed into high pressure, high temperature gas again and the cycle repeats.

FREEZE CYCLE

WATER SYSTEM

A combination of a solenoid water inlet valve with a water level sensor is used to control the level of the water into the reservoir or sump. A pump, running continuously, after the first 40" of freezing cycle, forces the water to the top of the evaporator, where it is distributed through a water tube and then cascades down

the evaporator surface by gravity. As it flows across the refrigerated evaporator, some of the water will be chilled enough to change form, turn to ice, and stay frozen onto the evaporator cells. Most of the water returns to the reservoir, to be sucked back into the pump, and re-pumped over the evaporator.

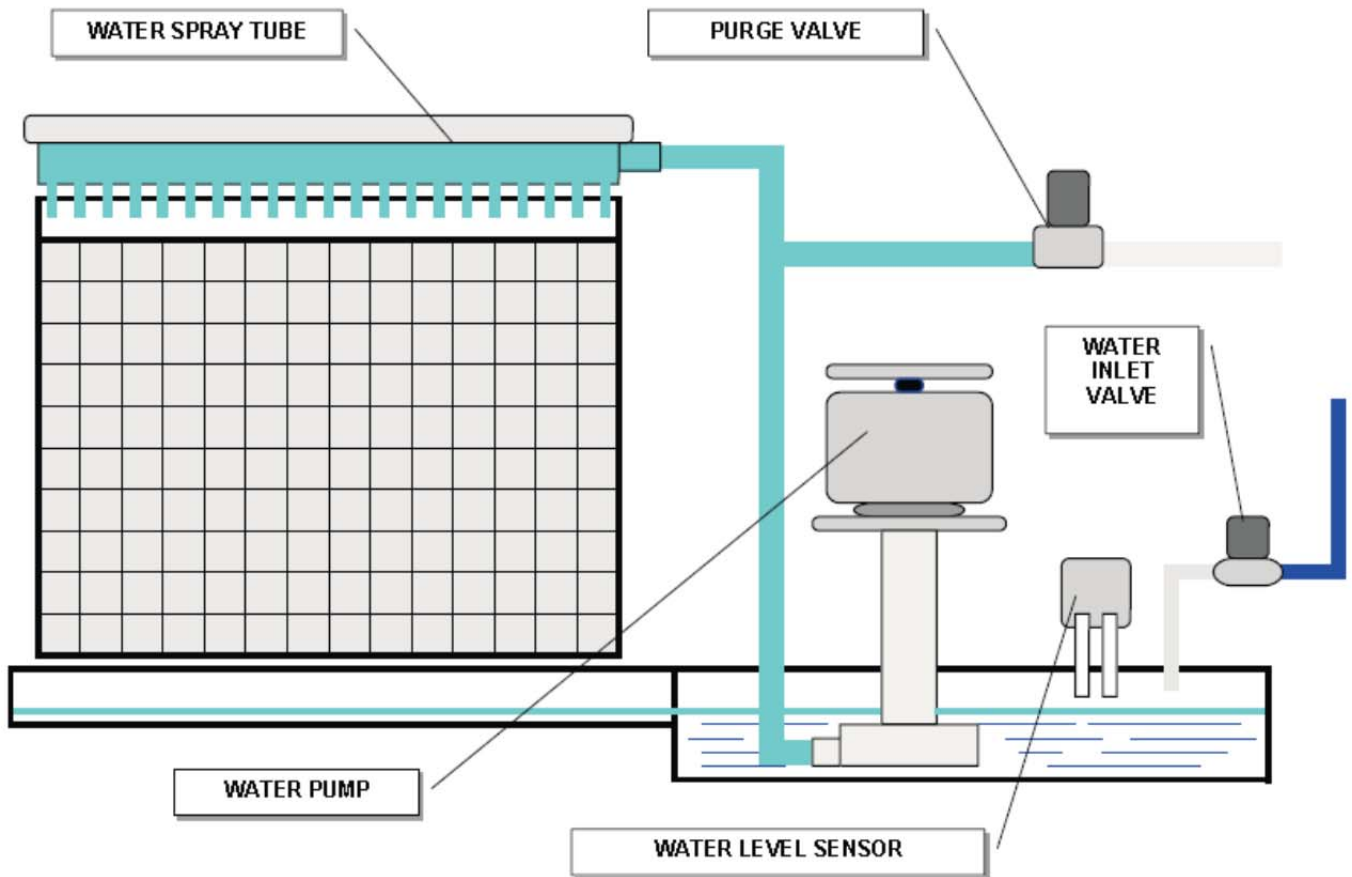

HARVEST CYCLE

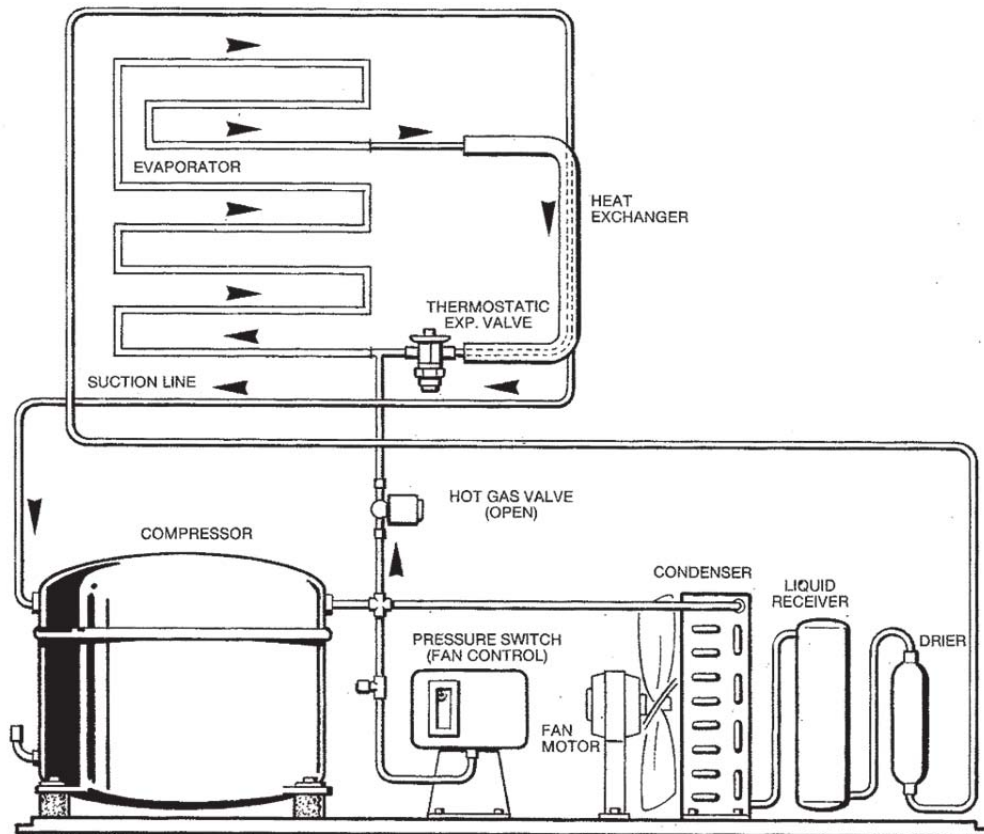

REFRIGERATION SYSTEM SCHEMATIC

REFRIGERATION SYSTEM DURING HARVEST

The refrigeration system performs the harvest of ice by use of a hot gas bypass valve. When the time comes to de-ice the evaporators, the harvest valve is energized, and the high temperature, high pressure gas bypasses the condenser, and is allowed directly into the evaporator. The high pressure gas is cooled by the cold evaporator so it condenses into a liquid, giving up its heat as it does so. This heat warms the evaporator and the ice frozen onto the evaporator surface melts, releasing the frozen cubes. Ice then falls by gravity into the storage bin.

The liquid refrigerant goes through the suction line into the heat exchanger where it boils-off so that only refrigerant vapor is drawn into the suction tube of the compressor.

WATER SYSTEM

During the harvest cycle, Purge Valve will according DIP Switch (#6) setup to purge water, 20" after the Purge Valve open drain

valve is energized thereby opening the drain line.

All water remained in the reservoir at the end of freezing cycle is pumped-out, to the waste, through the water purge valve and drain line, eliminating any possible build-up and accumulation of minerals concentration and impurities in the water reservoir.

20" after the Purge Valve open, the Water Inlet Solenoid Valve is energized for 10 seconds only in order to have a short flush of fresh water into the sump while the Water Pump and Purge valve are still in operation

When the released ice cubes drop into the bin, they open-up for a fraction of a seconds the bottom end of plastic deflector.

This deflector swinging motion is enough to reset the contact of the magnetic switch which - via PC board de-energizes the water drain valve allowing the unit to initiate a new freezing cycle. The harvest cycle lasts about 1-2.5 minutes.

CONTROL SEQUENCE

At the start of the freezing cycle, the contacts of the magnetic switch mechanically operated by the actuator plate of the deflector cover are closed, thereby - via PC board - closing the circuit to the main contactor or relay coil and consequently to the compressor and fan motors and 40" later, to the water pump motors.

Then, as the float valve ball location reaches the value that corresponds to the full cube size, for more than 6 seconds, a small relay of the PC board, get energized, controlling - simultaneously both the harvest valve and the water drain valve.

NOTE: in case of failure of ice level sensor, the PC Board turns - on automatically the unit into the defrost cycle when the freezing cycle reaches 30 or 40 minutes according to the operation of the fan motor during the freezing cycle.

At this point, the unit initiates the defrost cycle. The hot gas circulating into the evaporator serpentine causes a slight melting of ice cubes which get released from their molds. Once entirely released the ice cubes drop simultaneously into the ice storage bin below; by doing so they move apart from the evaporator bottom end the plastic deflector. This plastic deflector has on its side a magnetic switch that on account of the deflector swinging motion, caused by the ice while dropping in the bin, opens and closes their contacts. This will, in turn, deactivates the relay contacts that controls the hot gas and water drain valve which get de-energized allowing the unit to start a new freezing cycle. When the ice bin is full of ice, the last batch of ice cubes released from the evaporator accumulates to keep the bottom end of the plastic deflector in open position; with the magnetic switch contacts open for longer than 30" the entire unit stops with the glowing of the BIN FULL LED.

The machine will restart when the ice deflector will be back in its normal vertical position provided that 3' are elapsed from unit stop. If not the machine will delay its restart till 3' are elapsed with the blinking of the BIN FULL LED.

ALARM CONDITIONS



Both the last two red LED are on steady:

Condenser Sensor out of order. Both the last two red LED are blinking slow:

Water error.

Water level inside the water sump too slow after 3' or 6' from the activation of the Water Inlet Valve, according DIP Switch #4..

Both the last two red LED are blinking fast:

Water error recovery.

Every 30 minutes, Water inlet Solenoid Valve will open 180 seconds for recharge water after the tripping OFF on water error, If water full, the machine automatic reset.

Reset mode:

And press MODE button can go to start up cycle.



The fourth red LED is on steady: **3 times too long Harvest Cycle time** (according DIP Switch #3 setup),

The fourth red LED is blinking slow:

Too Hi condensing temperature error.

The condenser sensor detected a temperature $>70^{\circ}\text{C}$.

For the first 2 times, machine will automatic reset when temperature drop down. and the machine will stop when high temperature occurs the third time, ice machine will stop,

Reset mode:

And press MODE button can go to start up cycle.



The fifth red LED is on steady:
Too High discharge pressure,
 higher than 33 bar (460 PSI)
 For the first 2 times, machine will automatic reset when pressure drop down. and the machine will stop when high temperature occurs the third time, ice machine will stop,
Reset mode:
 And press MODE button can go to start up cycle.



Both the fourth red LED and second green LED are blinking fast:
5 times too long Freeze Cycle time
Reset mode:
 And press MODE button can go to start up cycle.



Both the third yellow LED and fourth red LED are blinking fast:
Ice thickness sensor fault
 When machine start, if PC board detect the ice thickness ON, machine will stop.
Reset mode:
 And press MODE button can go to start up cycle.



Both the fourth red LED and second yellow LED are blinking fast: **(For NW1408 only)**
Water temperature sensor fault
Reset mode:
 And press MODE button can go to start up cycle.

PC BOARD SET UP

The PC Board can be set up for:

MANUAL RESET MODE

To Restart the machine it is necessary to Push the MODE Button

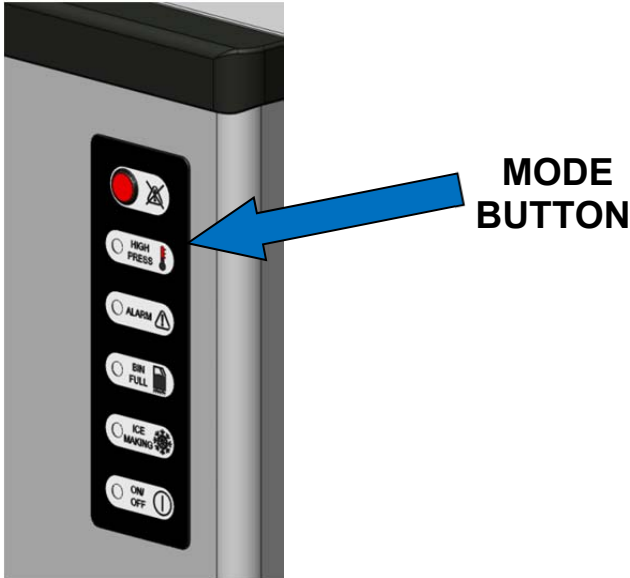

MODE BUTTON FUNCTION

Press MODE button can restart machine when machine in alarm.

When machine is working, press MODE button will going to next process as follow:
 Start -- Automatic clean -- Pressure balance -- Freezing -- Harvest -- Bin full

NOTE: There is same function MODE and CLEAN button in PC board and indicate board.

IMPORTANT: All PC board setup should be operated by authorized professional.

DIP SWITCH SETUP

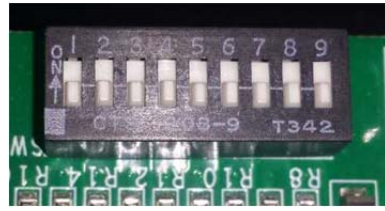

- #1 OFF For NW series
 ON For Factory use only

- #2 OFF No time delay
 ON Have 90' delay
 (For NW1008 & 1408only)

- #3 OFF 3.5' Longest harvest time
 ON 6' Longest harvest time

- #4 OFF 3.5' Longest water fills time
 ON 6' Longest water fills time

- #5 OFF Fill water in first 4' in freezing cycle
 ON Fill water in first 10'in freezing cycle

- #6 Water purge control
 #6-OFF/#7-OFF Water pump work 30"
 #6-ON/#7-OFF Water pump work 6" and 30" every sixth cycle.
 #6-OFF/#7-ON Water pump work 30" every three cycles.
 #6-ON/#7-ON Water pump work 30" every six cycles

- #8 OFF No water temperature sensor
 ON Have water temperature sensor
 (For NW1408 only)

- #9 OFF Machine will stop after clean procedure, need to press clean button to restart
 ON Machine will restart after clean procedure

DIP SWITCH FACTORY SETTING COMBINATIONS PER MODEL									
Model	Series	Per-heat	Harvest Cycle Time	Water Filling Time	Water Filling control	Water Purge Control		Water Temp. Sensor	Clean Setting
DIP SWITCH #	1	2	3	4	5	6	7	8	9
NW307/308 NW507/508 NW457/458 NW608	OFF	OFF	OFF	OFF	OFF	OFF	OFF	OFF	OFF
NW1008	OFF	ON	OFF	OFF	OFF	OFF	OFF	OFF	OFF
NW1408	OFF	ON	OFF	OFF	ON	OFF	OFF	ON	OFF

SERVICE SPECIFICATION

In servicing a machine, it is often useful to compare that individual unit operating characteristics to those of a normally operating machine. The data that follows gives those characteristics; however, be aware that these values are for new, clean machine operating at 21°C ambient and 10 °C water. Use these numbers as a guideline only.

COMPONENT

Reservoir Level

NW307/308.....	65~69mm
NW507/508.....	85~90mm
NW 457/458/608	80~85 mm
NW 1008	100~105 mm
NW1408	100~105 mm

Cube Size Control Float Valve Sensor
ICE bridge 3~5 mm

High Pressure Safety Switch

Cut in 23 bar
Cut out 33 bar

OPERATING CHARACTERISTICS

On air-cooled models during the freezing cycle, the discharge pressure is maintained between two preset values by means of fan control (condenser sensor); and at the same time, the suction pressure will also decline reaching its lowest point just before harvest. Compressor amps experience a similar drop.

On water-cooled, the discharge pressure is constantly, maintained during the freeze cycle by the water regulating valve. However, suction pressure and compressor amps, will still decline as the machine freezes ice.

Refrigerant	MODEL	Disch.Press. Freeze max	Disch. Press. Freeze min bar	Suction Press. Beginning Freeze	Suction Press. End Freeze	Freezing average cycle time	Comp. Amps. Beginning Freeze	Comp. Amps. Ending Freeze	Units Amps. After 5 min.
		bar	bar	bar	bar	min.	amp	amp	amp
R404A	NW308 AS 230/50/1	21	11	9	3	17			3.2
	NW308 AS 220/60/1								
	NW308 WS 230/50/1	17	16	4.2	2.2	17.5			3
	NW308 WS 220/60/1								
	NW458 AS 230/50/1	18	16	4.2	2.4	17.7			4.5
	NW458 AS 220/60/1								
	NW458 WS 230/50/1	17.3	17	3.2	1.7	18.3			4
	NW458 WS 220/60/1								
	NW508 AS 230/50/1	21	17	3.6	1.8	17			4.5
	NW508 AS 220/60/1								
	NW508 WS 230/50/1	17	16	3.4	2.8	17			4
	NW508 WS 220/60/1								
	NW608 AS 230/50/1	19.5	13	8	2.1	14.2			7.2
	NW608 AS 220/60/1								
	NW608 WS 230/50/1	17	17	3	1.4	13.4			6
	NW608 WS 220/60/1								
	NW1008 AS 230/50/1	19.5	12	6.3	2.2	14			10.6
	NW1008 AS 220/60/1								
	NW1008 AS 400/50/3	20	12	6.9	2.1	14			5.4
	NW1008 AS 220/60/1								
NW1008 WS 230/50/1	19	16	4	2	16			8	
NW1008 WS 220/60/1									
NW1008 WS 400/50/3N	17	17	3.5	1.7	14.4			3.9	
NW1408 AS 230/50/1	22.4	12.4	6.6	2.7	13.3			11.8	
NW1408 AS 220/60/1									
NW1408 WS 230/50/1	19	13	6.5	2.5	13			11.4	
NW1408 WS 220/60/1									

Refrigerant	MODEL	Disch.Press. Freeze max	Disch. Press. Freeze min bar	Suction Press. Beginning Freeze	Suction Press. End Freeze	Freezing average cycle time	Comp. Amps. Beginning Freeze	Comp. Amps. Ending Freeze	Units Amps. After 5 min.
		bar	bar	bar	bar	min.	amp	amp	amp
R452A	NW308 AS 230/50/1	18	13	4.2	2.4	17			3.18
	NW308 AS 220/60/1								
	NW308 WS 230/50/1	17.5	15.8	3.6	2	18			3.1
	NW308 WS 220/60/1								
	NW458 AS 230/50/1	17	11	3	1.8	16			4.31
	NW458 AS 220/60/1								
	NW458 WS 230/50/1	18	17.5	3	1.4	15			5.18
	NW458 WS 220/60/1								
	NW508 AS 230/50/1	15.4	14	3.4	2	13			6
	NW508 AS 220/60/1								
	NW508 WS 230/50/1	16	15.5	3.2	1.6	14			5.24
	NW508 WS 220/60/1								
	NW608 AS 230/50/1	17	14	2.6	1.4	14			7.5
	NW608 AS 220/60/1								
	NW608 WS 230/50/1	17	16	3	1.4	15			6
	NW608 WS 220/60/1								
	NW1008 AS 230/50/1	17.5	14.5	3.2	1.7	12			10.16
	NW1008 AS 220/60/1								
	NW1008 AS 400/50/3N	21	11	6.6	2.3	15			4
	NW1008 WS 230/50/1	18	17	3	1.7	13			9.28
NW1008 WS 400/50/3N									
NW1408 AS 230/50/1	20	12	7.6	2.8	13.4			11.7	
NW1408 AS 220/60/1									
NW1408 WS 230/50/1	22	14	6.8	2.9	13			11.5	
NW1408 WS 220/60/1									

Refrigerant	MODEL	Disch.Press. Freeze max	Disch. Press. Freeze min bar	Suction Press. Beginning Freeze	Suction Press. End Freeze	Freezing average cycle time	Comp. Amps. Beginning Freeze	Comp. Amps. Ending Freeze	Units Amps. After 5 min.
		bar	bar	bar	bar	min.	amp	amp	amp
R290	NW307 AS 230/50/1	14	10	3	1.2	13	4	3.4	4
	NW507 AS 230/50/1	14	11	2.4	1.4	15	4.17	3.6	4
	NW457 AS 230/50/1	12	11	3	1.8	17	4.2	3.7	4.1

Refrigerant charge value (All units are gram)

Refrigerant charge R404A

MODEL	NW308	NW508	NW458	NW608	NW1008	NW1408
Air cooled 230/50/1	460	730	650	900	1350	2200
Air cooled 220/60/1	460	730	650	900	1350	2200
Air cooled 400/50/3N	-----	-----	-----	-----	1600	-----
Water cooled 230/50/1	320	500	500	550	1200	1800
Water cooled 220/60/1	300	500	500	550	1200	1800
Water cooled 400/50/3N	-----	-----	-----	-----	1200	-----

Refrigerant charge R452A

MODEL	NW308	NW508	NW 458	NW 608	NW1008	NW1408
Air cooled 230/50/1	550	800	700	950	1350	2200
Air cooled 220/60/1	550	800	700	950	1350	2200
Air cooled 400/50/3N	-----	-----	-----	-----	1600	-----
Water cooled 230/50/1	380	500	500	550	1200	1800
Water cooled 220/60/1	380	500	500	550	1200	1800
Water cooled 400/50/3N	-----	-----	-----	-----	1200	-----

Refrigerant charge R290

MODEL	NW307	NW507	NW457
Air cooled 230/50/1	149	149	149

NOTE: Always check nameplate on individual ice machine for special refrigerant charge before charging the refrigeration system. Such refrigerant charge is the average charge for the NW Modular Cubers. However it is important to check nameplate of each machine.

COMPONENT DESCRIPTION

1. Front Console Panel

A		BUTTONA Reset/Washing
1		LEDNo.1 Alarm high pressure
2		LEDNo.2 Alarm
3		LEDNo.3 Bin full.
4		LEDNo.4 Operation
5		LEDNo.5 Electrical power supply

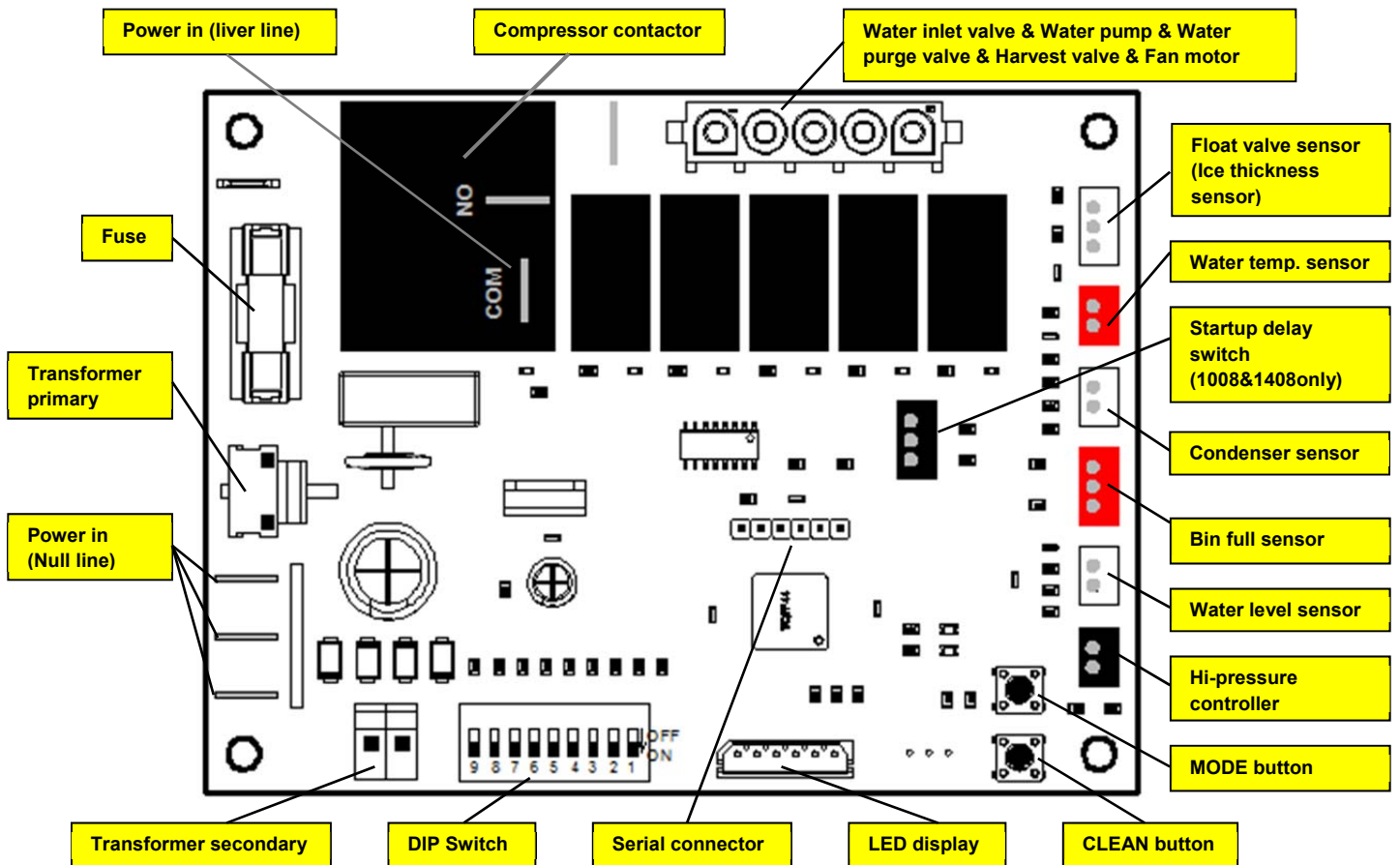

2. P.C. Board (As above picture)

Located in the control box, this board is the brain of the system as it governs the ice machine cyclematic through sensors, relays and switches. It consists of two separated printed circuits one at high and the other at low voltage integrated with a fuse, of seven

connectors for the sensors/switches (as above picture), of one outlet connector (front LED display), of one serial port connector, of two 2-PIN plug for transformer input and output power, of two terminals for input power live line and compressor output, of 3 terminals for power null line, of one 5-PIN plug for components output, and two buttons for

MODE and clean, and one DIP Switch for PC board setup.

3. Compressor Contactor or Relay (Except NW308)

Located in the control box or compressor accessory box, the compressor contactor or relay functions to carry the compressor line current. The contactor or relay is wired to receive power from the P.C. Board.

(NW308 compressor is wired to P.C. Board relay directly.)

4. Float Valve Sensor

Located on right of evaporator and upper of water sump, the sensor is made composed of reed switch and float ball, float ball within the magnetic material with magnet, are set through a setting screw to change the level of sensor bracket, to maintain ice bridge is about 3~5 mm. Once ice is formed into each mold and the water level in water sump go down, Float Valve Sensor will send signal to P.C. Board, it means ice thick enough.

After the P.C. Board receives the signals to and delay about 10 seconds, then put the ice machine on Harvest cycle.

5. Magnetic Switch

Located in the front of the evaporator plastic curtain, this switch sends a pulse to the P.C. Board which switches the machine back in the freezing cycle.

6. Hot Gas Solenoid Valve

The Hot Gas Solenoid Valve functions only during the Harvest Cycle, to divert the hot discharge gas from the Compressor, bypassing the Condenser and thermostatic expansion valve, for direct flow to the Evaporator Plate Assembly to release ice cubes from the ice cube molds.

The Harvest Solenoid Valve is comprised of two parts, the Body & Plunger and the Coil assemblies.

Installed in the discharge line of the Compressor, the energized solenoid coil lifts the valve stem within the valve body to cause the hot discharge gas to be diverted when the ice Thickness sensor has signaled to the P.C. Board to start the Harvest Cycle.

7. Condenser temperature sensor

The condenser temperature sensor probe (located in contact with the condenser tube coil) detects the condenser temperature variations and signals them by supplying current, at low voltage, to the P.C. BOARD.

In the air cooled versions, in relation to the different current received, the micro processor of the P.C. BOARD supplies, through a TRIAC, the power at high voltage to the fan motor so to cool the condenser and to reduce its temperature.

In case the condenser temperature rises and reaches 70°C (158°F) the current arriving to the microprocessor is such to cause an immediate stop of the machine operation with the blinking of the Red LED, and first two time machine will automatic restart, the machine will total stop when high temperature occurs the third time, And press MODE button can go to start up cycle.

8. High Pressure Control

The high Pressure Control, a safety control, is factory set to cut-out, at 33 bars and cut-in at 22 bars. The control, functions as a precautionary device to shut OFF electrical power to Icemaker, should a loss of water occur to the water cooled Condenser or a burnt out of the fan motor on air cooled versions. The high Pressure Control is manual reset with reset button located on the rear side of the machine and a monitoring light on the Front Console Panel.

9. Water Regulating Valve

(Water Cooled Models)

The Water Regulating Valve functions maintain a constant Compressor head pressure, by regulating the amount of incoming water flow through the Condenser, on water-cooled models. The valve operates through the refrigerant system high side pressure. Rotating the adjusting screw located on top of the valve, can INCREASE or DECREASE the water flow through the water-cooled Condenser, which in turn, will DECREASE or INCREASE the Compressor operating head pressure.

10. Water Distribution System

The Water Distribution System functions to

even supply water to all cells of the evaporator plate. The water pump pumps water from the sump to the tee. From there water is channeled through the vertical PVC tube to the water distributors, above the evaporator plate, and from the holes in the distributor tube water flows to the cells on one side of the evaporator plate.

Gravity flow returns the unfrozen excess portion of water to the sump reservoir for recirculation.

11. Water Purge Solenoid Valve

The Water Outlet Solenoid Valve functions in conjunction with the water pump to flush-out the sump assembly as DIP switch #6 setup. This action cleans-up and rinses the sump during each harvest cycle preventing dangerous water minerals concentration.

12. Thermostatic Expansion Valve

The Thermostatic Expansion Valve regulates the flow of refrigerant to the evaporator and reduces pressure of liquid refrigerant from condensing pressure to evaporating pressure.

13. Water pump

The water pump primes the water from the sump to the water distributor tube and through the distributing holes it cascades down onto the evaporator cells by gravity so to be frozen into clear ice cubes. The water pump remains off during the first 40" seconds of the freezing cycle (to avoid any cavitations problem).while it's kept running during as DIP switch #6 setup.

14. Water inlet solenoid valve - 3/4" male fitting

The Water Inlet Solenoid valve is energized by the P.C. Board during the beginning of the freezing cycle till the water reaches the maximum level into the sump (controlled by the Water Level Sensor).

After 3 minutes, from the start up of the freezing cycle, the Water Inlet Valve is energized again for a short period to re-fill the sump with water till again to the maximum level so to minimize any possibility of slush ice formation

A flow control, fitted into its outlet port, reduces the pressure of the water flow.

15. Water level sensor

The Water Level Sensor, located on the upper right side of the water sump, works in conjunction with the P.C. Board in order to control the water level at beginning of the freezing cycle by receiving a low power current passing through the water. When the current reaches the PC Board, the water inlet solenoid valve is de-energized.

In case the PC Board doesn't receive any signal(current) as DIP switch #4 setup from the Water Level Sensor, the PC Board trips OFF the operation of the machine with the switching ON of the Water Error LEDs.

16. Start up delay PC Board by-pass switch

Located in the back side of the machine allows to by-pass the delay time controlled by the delay PC Board.

WARNING: It is IMPERATIVE to by-pass the delay time only when sure of proper warm up of compressor.

17. Harvest assist (For NW307/507/457 only)

The Harvest Assist running in Harvest Cycle, It will push the ice cubers out, so decrease Harvest Cycle time and increase production.

18. LED display



Located in the upper and right side of the machine when remove the front panel.

- 1 -- Power light (Green)
- 2 -- Freezing light (Green)
- 3 -- Bin full light (Yellow)
- 4 -- Alarm light (Red)
- 5 -- High pressure alarm light (Red)
- 6 -- Clean light (Red)
- 7 -- Harvest light (Yellow)
- B1 -- Mode button
- B2 -- CLEAN button

Closed Loop Scotsman® Sanitation System XSAFE

This unit is equipped with a natural sanitation system integrated inside the machine that ensures absolute cleaning and hygiene. This system is based on UV-Lamp - Ozone Technology Air Treatment of the Ice Machine

Food Zone.

- Keep ice machines, ice bins clean
- Reduce equipment cleanings and associated costs
- Reduce yeast, viruses and other microorganisms
- Decrease technical malfunctions and equipment downtime
- Completely automated and chemical-free
- Maintenance free – requires a simple annual UV lamp replacement

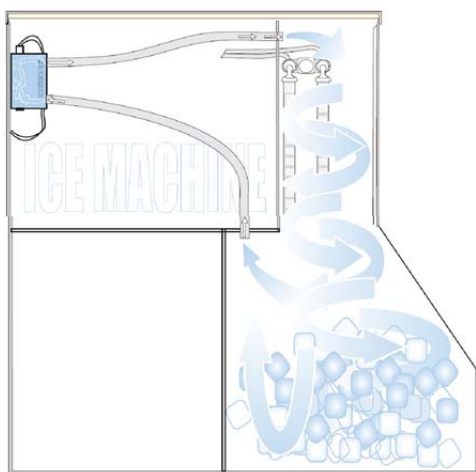

This system requires annual maintenance program in order to maintain its efficiency operation. It requires a simple annual UV lamp replacement. **Please contact your local Scotsman dealer for annual maintenance program**

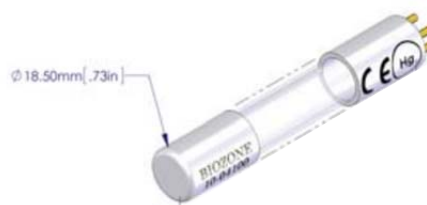

UV Lamp

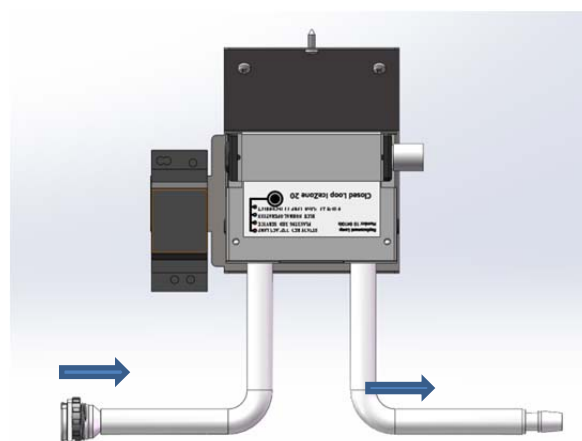

Sanitation System



WARNING: These procedures should only be performed by a qualified electrician according to national and local electrical codes. Supply power should be turned off during installation or when replacing components or checking connections. Never perform maintenance or cleaning while fixture is energized.

This device only accepts Scotsman Ice replacement lamp part number SC630102 00

STEADY RED: REPLACE LAMP
 FLASHING RED: SERVICE
 BLUE: NORMAL OPERATION
 RED/BLUE FLASH: LAMP ID INCORRECT

Scotsman XSafe

Safety Instructions

Inspect the device for damage that may have occurred during transportation. If the unit has been damaged, do not connect it to the power supply or try to use it otherwise. In the event of damage, immediately contact Scotsman authorized service.

The installation may not be carried out in such a way that it damages electronic components, ice maker components or wiring. Furthermore, installation must not require any modification to or re-positioning of ice maker components.

Before installation or maintaining, disconnect the ice maker from the power supply.

This appliance is not intended for use by persons (including children) with reduced physical, sensory or mental capabilities, or lack of experience and knowledge, unless they have been given supervision or instruction concerning use of the appliance by a person responsible for their safety. Children are not allowed to use or play with this appliance and should be supervised to ensure this.

Use only spare parts approved by Scotsman.



UV WARNING – Eye damage may result from directly viewing the light produced by the lamp in this apparatus. Always turn off lamp before opening cover.



WARNING – High voltage inside. Open Circuit Voltage and Voltage to Ground: 600V.



Dispose of this device or any related parts in accordance with all international, federal, state, and local regulations.



The bulb in this product contains mercury. Call or visit LampRecycle at +1-866-666-6859 or www.lamprecycle.org

Maintenance Instructions

If the device is located in a dusty or smoke-filled area, it is recommended that the bulb be cleaned every three months, as this will significantly extend the life of the bulb. At a minimum, the bulb must be changed every twelve months in order to ensure maximum functionality and efficiency.

Bulb Replacement Instructions

1. Disconnect the power supply to the ice machine
2. Access the device by removing the necessary covers and access panels on the ice machine, as instructed in ice machine owner's manual (not supplied)
3. Disconnect the power supply to the device
4. Disconnect the lamp holder from the bulb by gripping the plastic lamp holder body and pulling away from the bulb. **Do not grip the lamp holder by the connecting wires under any circumstances as this is a high voltage hazard.** The 4 pins on the "pin-end" of the bulb will be exposed
5. Push the flat end bulb through the end cap of the "flat-end" until approximately 1 inch of the bulb has moved through the "pin-end" end cap
6. Pull the remainder of the bulb from the "pin-end." Remove either end cap if attached to the bulb
7. Ensure that the bulb has cooled down. **When handling the bulb, avoid touching the glass element with exposed fingers as oil and residues from skin can adversely affect the performance of the bulb**
 - a) Cleaning the bulb: Clean the bulb with a soft cloth and an appropriate cleansing solvent compatible with quartz glass (such as rubbing alcohol). Cleansing wipes may also be used; Reinsert the bulb
 - b) Changing the bulb: Insert a new bulb (see technical specifications in this manual for correct bulb type). Use only a new BioZone Scientific International bulb (using other bulb will void the warranty)
8. Replace the bulb by inserting the "flat-end" into the appropriate end cap. Insert the "pin-end" end cap
9. Reconnect the lamp holder to the "pin-end" of the bulb
10. Reconnect the power supply to the device
11. Replace any access panel removed on the ice machine
12. Reconnect the power supply to the ice machine
13. Dispose of any old bulbs in accordance with all regulations pertaining to hazardous waste disposal (these bulbs contain small traces of mercury)

NW 308- WIRING DIAGRAM

230V~ / 50HZ / 1PH & 220 V~ / 60HZ / 1PH

br = brown
 b = blue
 yg = yellow / green
 w = white
 bk= black

r = red
 o = orange
 p = purple
 g =green
 y =yellow

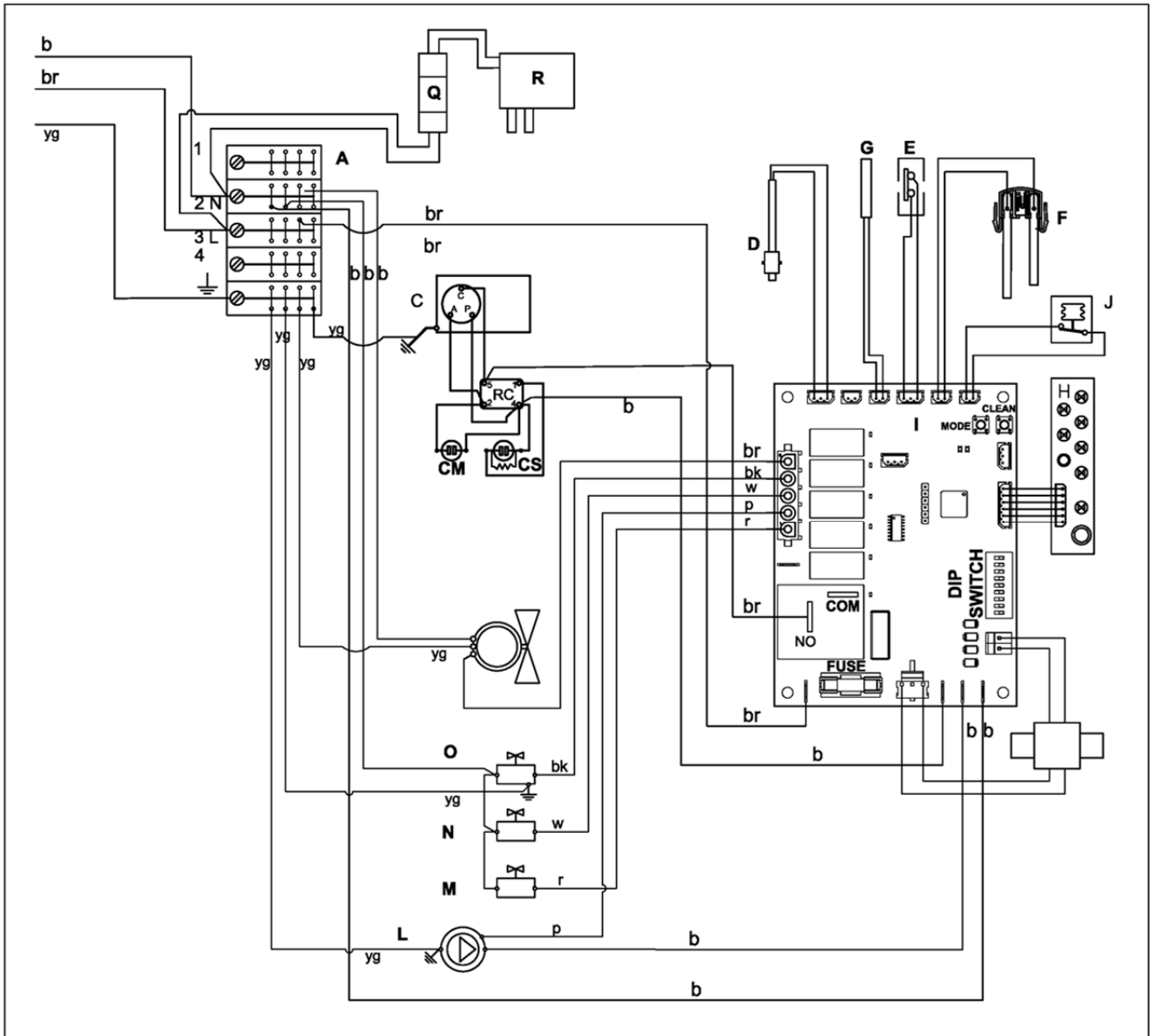

- | | | | |
|---|----------------------|---|-------------------------------|
| A | TERMINAL BLOCK | J | MAX PRESSURE SWITCH |
| C | COMPRESSOR | L | WATER PUMP |
| D | ICE THICKNESS SENSOR | M | WATER INLET VALVE |
| E | ICE FULL SENSOR | N | WATER PURGE VALVE |
| F | WATER LEVEL SENSOR | O | DEFROST VALVE |
| G | CONDENSER SENSOR | P | FAN MOTOR (AIR COOLED ONLY) |
| H | UIM BOARD | Q | CLIZ-2 TRANSFORMER (ONLY OX) |
| I | PC BOARD | R | CLOSED LOOP ICEZONE (ONLY OX) |

NW 307/507/457- WIRING DIAGRAM

230V~ / 50HZ / 1PH

br = brown

b = blue

yg = yellow / green

w = white

bk= black

r = red

o = orange

p = purple

g =green

y =yellow

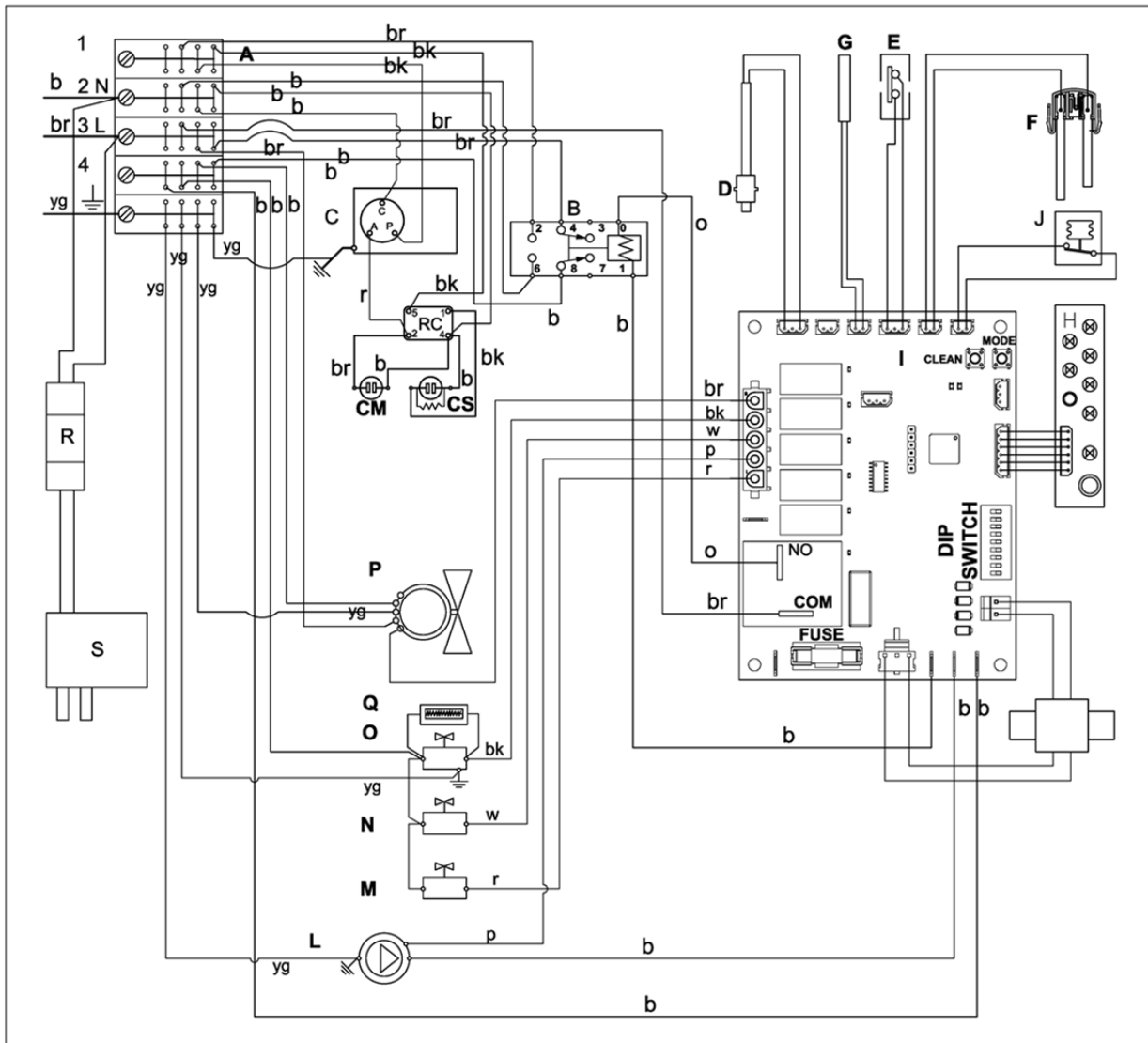

A TERMINAL BLOCK

B POWER RELAY

C COMPRESSOR

D ICE THICKNESS SENSOR

E ICE FULL SENSOR

F WATER LEVEL SENSOR

G CONDENSER SENSOR

H UIM BOARD

I PC BOARD

J MAX PRESSURE SWITCH

L WATER PUMP

M WATER INLET VALVE

N WATER PURGE VALVE

O DEFROST VALVE

P FAN MOTOR (AIR COOLED ONLY)

Q HARVEST ASSISTS

R CLIZ-2 TRANSFORMER (ONLY OX)

S CLOSED LOOP ICEZONE (ONLY OX)

NW 508/458/608- WIRING DIAGRAM

230V~ / 50HZ / 1PH & 220 V~ / 60HZ / 1PH

m = brown

bc = blue

gv = yellow / green

b = white

n = black

r = red

a = orange

v = purple

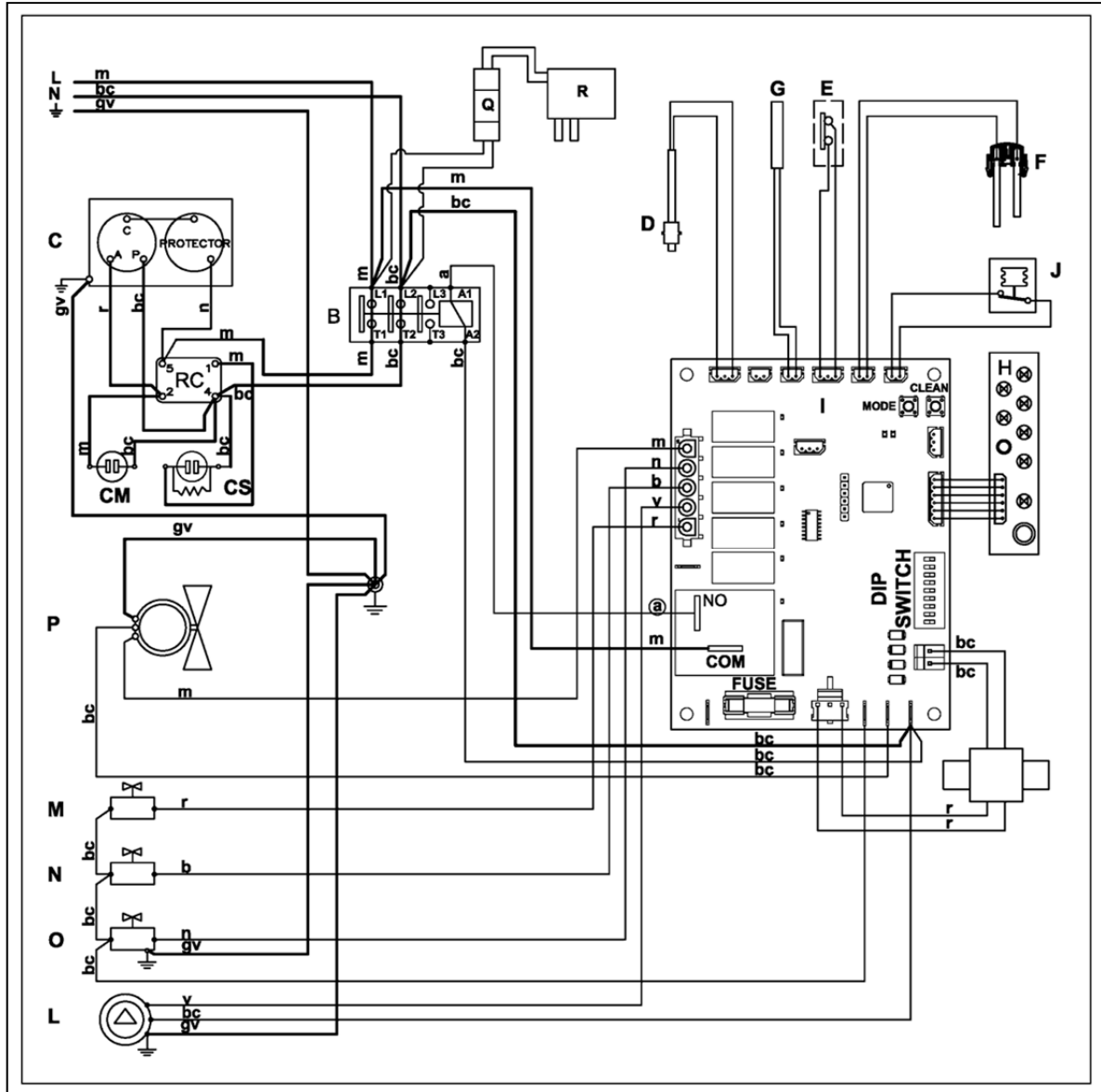

B COMPRESSOR CONTACTOR

C COMPRESSOR

D ICE THICKNESS SENSOR

E ICE FULL SENSOR

F WATER LEVEL SENSOR

G CONDENSER SENSOR

H INDICATE BOARD

I PC BOARD

J MAX PRESSURE SWITCH

M WATER INLET VALVE

N WATER PURGE VALVE

O DEFROST VALVE

P FAN MOTOR (FOR AIR ONLY)

Q CLIZ-2 TRANSFORMER (OX ONLY)

R CLOSED LOOP ICEZONE (OX ONLY)

RC COMPRESSOR RELAY

CS START CAPACITOR

CM RUNNING CAPACITOR

NW 1008/1408 - WIRING DIAGRAM

230V~ / 50HZ / 1PH

m = brown
bc = blue
gv = yellow / green
b = white
n = black

r = red
a = orange
v = purple
g = green
y = yellow

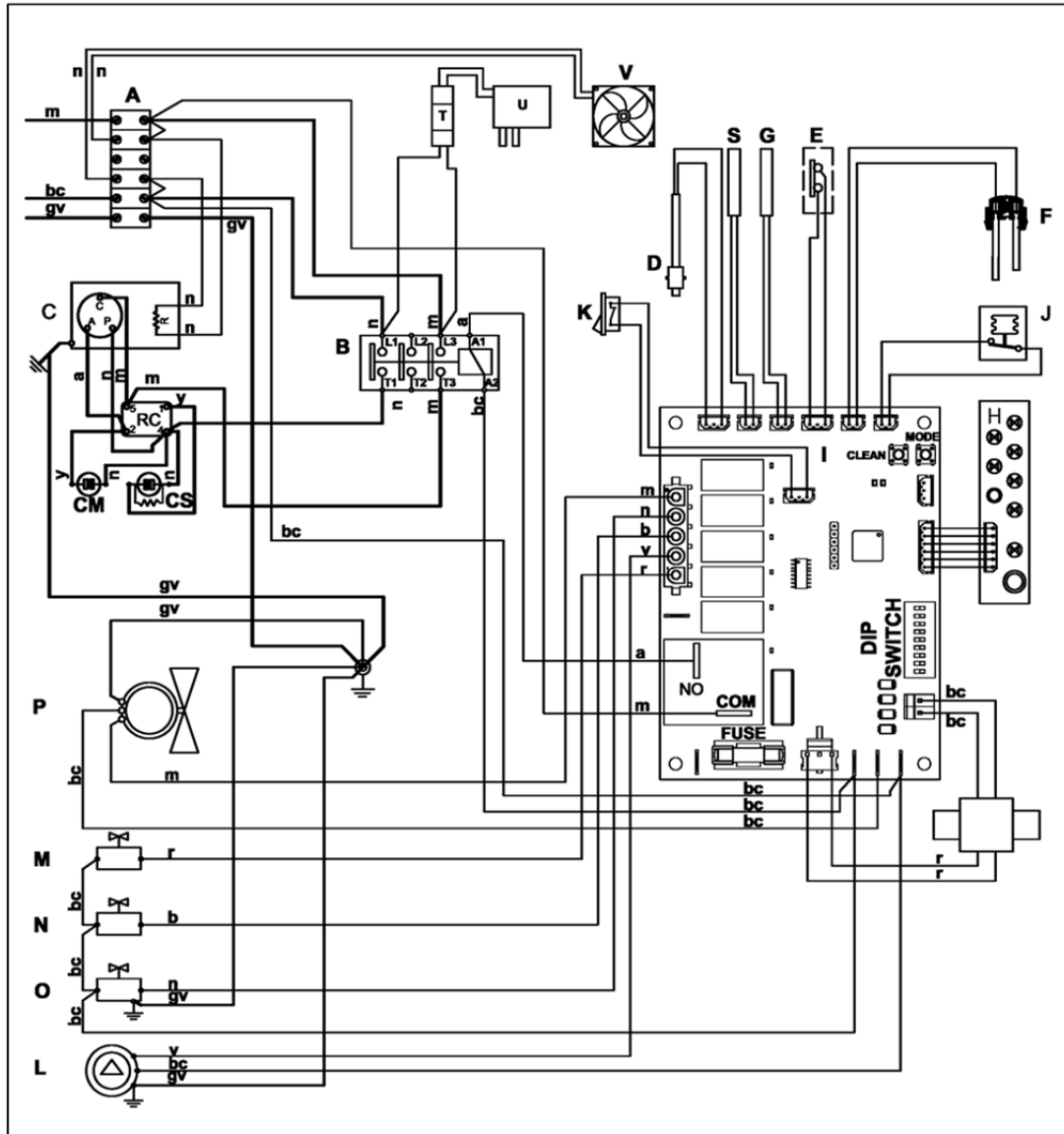

- | | | | |
|---|----------------------|---|------------------------------------|
| A | TERMINAL BLOCK | L | WATER PUMP |
| B | COMPRESSOR CONTACTOR | M | WATER INLET VALVE |
| C | COMPRESSOR | N | WATER PURGE VALVE |
| D | ICE THICKNESS SENSOR | O | DEFROST VALVE |
| E | ICE FULL SENSOR | P | FAN MOTOR (FOR AIR ONLY) |
| F | WATER LEVEL SENSOR | R | CRANKCASE HEATER |
| G | CONDENSER SENSOR | S | WATER TEMP. SENSOR (FOR 1408 ONLY) |
| H | INDICATE BOARD | T | CLIZ-2 TRANSFORMER (OX ONLY) |
| I | PC BOARD | U | CLOSED LOOP ICEZONE (OX ONLY) |
| J | MAX PRESSURE SWITCH | V | FAN (FOR 1408W ONLY) |
| K | OFF-DELAY SWITCH | | |

NW 1008 - WIRING DIAGRAM

400V~ / 50HZ / 3 PH

m = brown
 bc = blue
 gv = yellow / green
 b = white
 n = black

r = red
 a = orange
 v = purple
 g = green

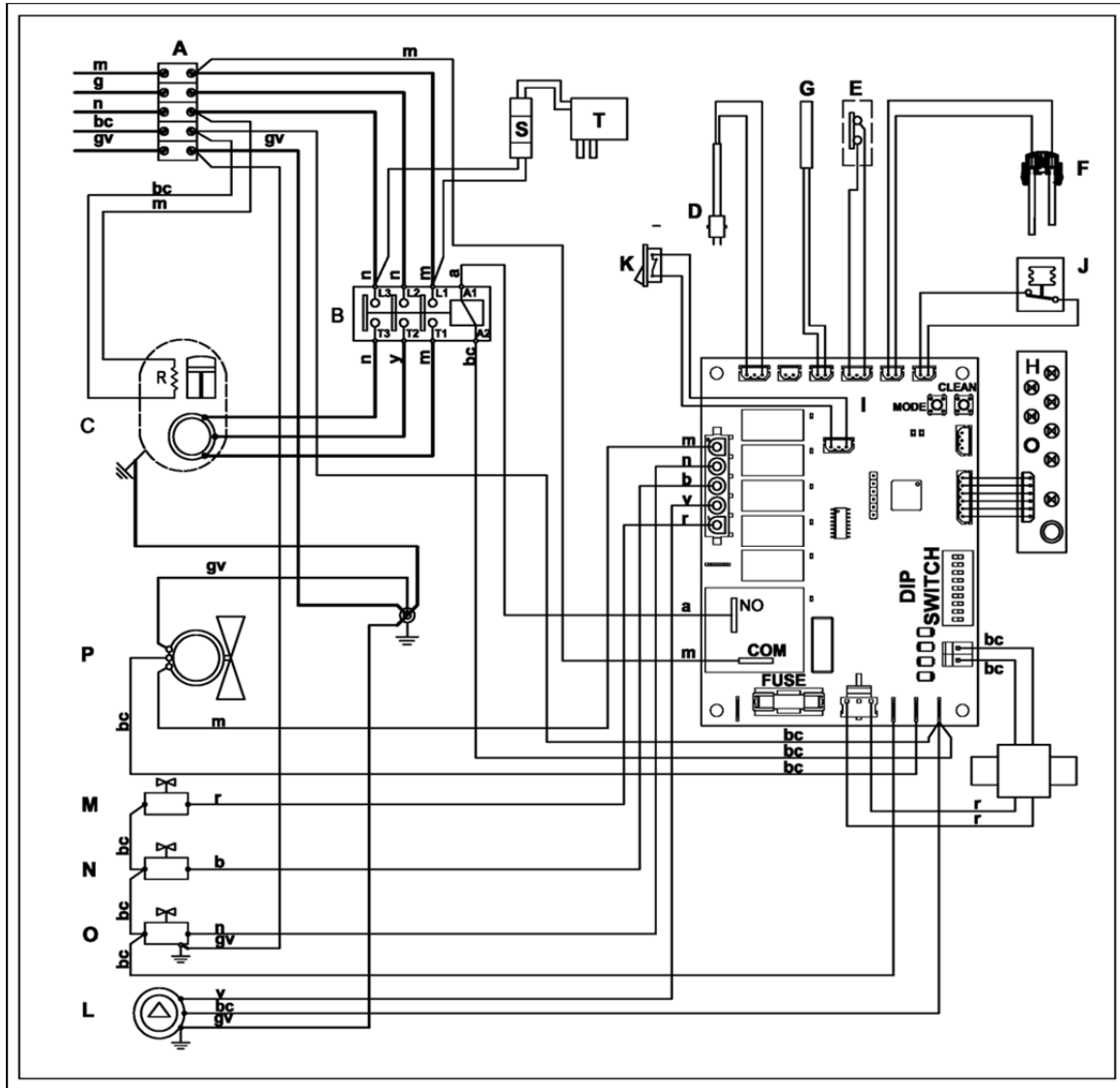

- A TERMINAL BLOCK
- B COMPRESSOR CONTACTOR
- C COMPRESSOR
- D ICE THICKNESS SENSOR
- E ICE FULL SENSOR
- F WATER LEVEL SENSOR
- G CONDENSER SENSOR
- H INDICATE BOARD
- I PC BOARD
- J MAX PRESSURE SWITCH

- K OFF-DELAY SWITCH
- L WATER PUMP
- M WATER INLET VALVE
- N WATER PURGE VALVE
- O DEFROST VALVE
- P FAN MOTOR (FOR AIR ONLY)
- R CRANCKASE HEATER
- S CLIZ-2 TRANSFORMER (OX ONLY)
- T CLOSED LOOP ICEZONE (OX ONLY)

SERVICE DIAGNOSIS



The table below is intended as a quick reference to aid the Service Agent in determining the cause of a particular type of malfunction, as well as the recommended repair. It is not intended to be an exclusive list.

Reference to other portions of this manual, including wiring diagrams, installation, and operation are recommended to better determine the cause of a problem.

SYMPTOM	POSSIBLE CAUSE	CORRECTION
Warning Red LED ON	See page 23-24	See page 23-24
No warning LED/LIGHT ON	P.C. Board inoperative. No power to unit.	Remove board and check. Check electrical source.
Bin full Yellow LED ON	Bin Full of ice.	None.
Machine runs, compressor does not.	P.C. Board compressor relay open. Compressor contactor open. Compressor relay open. Compressor winding open.	Test and replace. Test and replace. Test and replace. Test and replace.
Machine runs, makes ice, does not try to harvest.	Ice thickness control open. Too soft water. Built-in relay on P.C. Board open.	Check sensor fingers if are not covered with scale sediment. Water electrical conductivity must be higher then 20 μ s. Machine can't run with demineralized water. Check and replace P.C. Board.
Machine runs, makes and harvests ice but very slowly.	Low refrigerant charge.	Check system for correct refrigerant charge. Check for leak weight in charge.
Low ice capacity.	High discharge pressure due to not-condensable or overcharge. Inefficient compressor. Condenser dirty. Low water flow (Water-cooled). High air temperature (air-cooled).	Evacuate and weigh in charge. Replace. Clean. Check and repair. Check temperature of air entering condenser.
Machine makes irregular ice.	Plugged water distributor. TXV superheat wrong. Refrigerant charge low.	Clean water distributor. Adjust or replace. Adjust-check for leak. Recharge.

MAINTENANCE & CLEANING & SANITATION INSTRUCTIONS

A SCOTSMAN Ice System represents a sizable investment of time and money in any company's business. In order to receive the best return for that investment, in MUST receive periodic maintenance.

It is the USER'S RESPONSIBILITY to see that preferable, and less costly in the long run, to avoid possible down time by keeping it clean, adjusting it as needed and by replacing worn parts before they can cause failure. The following is a list of recommended maintenance that will help keep your machine running with a minimum of problems.

ICEMAKER

IMPORTANT:
THE FOLLOWING MAINTENANCE AND CLEAN SHOULD BE SCHEDULED AT LEAST TWO TIMES PER YEAR ON THIS ICEMAKER. CALL YOUR AUTHORIZED SCOTSMAN SERVICE AGENCY.

1. Check and clean or service any optional water treatment devices, if any installed.
2. Clean water strainer.
3. Check that the cabinet is level, in the side-to-side and front-to-back directions.
4. Clean/Sanitize the water system, evaporator plate and sump assembly, using a solution of Ice Machine Cleaner/Sanitizers. Refer to CLEANING - Icemaker.

NOTE:

Cleaning/Sanitizing requirements vary according to local water conditions and individual user operation.

Continuous check of the clarity of ice cubes and visual inspection of the water system parts, evaporator plates and the sump assembly before and after cleaning will indicate frequency and procedure to be followed in local areas.

5. Check and tighten all bolts and screws.

6. Check for water leaks and make corrections.

7. Check the bin control to test shut-off. Holding the evaporator deflector in open Position for more that 30", should cause the ice maker to shut-off.

Once the evaporator deflector is released in its closed position, the ice maker will restart.

8. Check cube size; adjust if required through setting screw of ice thickness control sensor.

9. With unit out of operation, clean the condenser using vacuum, cleaner, wisk broom or brush. Instruct customer to clean condenser frequently

DO NOT USE A WIRE BRUSH.

ICE STORAGE BIN

The interior liner of the bin is in contact with a food product, ice, and should be cleaned and sanitized regularly. Once a week sanitize it with a commercial food grade sanitizers complying with the manufacturer dilution.

CABINET EXTERIOR

Wipe clean unit and bin cabinet exterior with a clean cloth or disposable paper wipers, soaked in warm water with mild detergent solution.

CLEANING - ICEMAKER

WARNING - Ice Machine Cleaner contains Phosphoric and Hydroxyacetic acids. These compounds are corrosive and may cause burns. If swallowed, DO NOT induce vomiting. Give large amounts of water or milk. Call physician immediately. In case of external contact, flush with water. KEEP OUT OF THE REACH OF CHILDREN.

1. Empty bin of ice.
2. Remove front panel.
3. Wait till the end of the harvest cycle, switch off the machine, then switch ON again, push the CLEAN BUTTON on LED display for 2-3 seconds in one minute. The machine should go to clean/sanitize procedure, and the red CLEAN LED light on LED display will be fast blinking in whole procedure.

4. In beginning 30" of clean procedure, machine will purge water from sump, then pour on

- NW307/308	185cc
- NW507/508	210cc
- NW 457/458-608	250 cc
- NW1008	350 cc
- NW1408	350cc

of Scotsman Ice Machine Cleaner directly into the reservoir while the water inlet valve will be energized till the fill up of the water sump. The water pump starts to operate.

5. After 10 minutes, machine will purge the clean Cleaner solution, and refill up the water sump, then go into automatic rinsing mode.

NOTE: RINSING mode consists of:

- a) Energize the water pump for 30".
- b) Energize the water drain valve and the water pump for 30".
- c) Energize the water inlet valve till the fill up of the water sump.

The above sequence is repeated 10 times so to be sure to have removed any possible trace of Ice Machine Cleaner.

6. At the end of the 10th Rinsing cycle, according DIP switch #9 setup, the machine:

#9 OFF machine stops the operation and blinking (slow) of the red Clean LED.

Push the CLEAN BUTTON when machine stop, the machine restarts in the freezing cycle

#9 ON Machine will go to freezing cycle directly.

7. Replace the evaporator cover deflector and front panel.

8. Check the next batch of cubes to be sure all the cleaner is gone (no sour taste).

CAUTION:
DO NOT use ice cubes produced from the cleaning solution. Be sure none remains in the bin.

9. Pour hot water into the storage bin melt the cubes, and to also clean the bin drain.

Scotsman[®]

Ice Systems

EUROPE, MIDDLE EAST & AFRICA

Scotsman Ice s.r.l.
Via Lainate 31
20020 Pogliano Milanese (MI) – ITALY
www.scotsman-ice.it - info@scotsman-ice.it
Tel. +39 02 93960350 - Fax +39 02 93540449

Scotsman Industries Singapore Pte Ltd

140 Paya Lebar Road Singapore 409015

www.scotsman-ice.it

scotsman@scotsman.com.sg

Tel. +65 6738 5393 - Fax +65 6738 1959

Scotsman Ice Systems (Shanghai) Co., Ltd.

Address:

Room 2505, Building 2, No 20 Xuhong Middle Rd,
Shanghai, China. 200235

Phone: 0086-21-61313200

Fax: 0086-21-61313330

Hotline: 0086-4006300076

E-Mail: sales@scotsman-china.com

Website: www.scotsman-china.com

Manufacturer:

Scotsman Ice Systems (SuZhou) Co., Ltd

Building 5, No. 525 South Lingang RD, Yuewang, Shaxi
Town, Taicang City, Jiangsu Province China 215437